



life.augmented

STM32G4 mainstream series mixed signal MCU





STM32G4 series continuity of the STM32F3

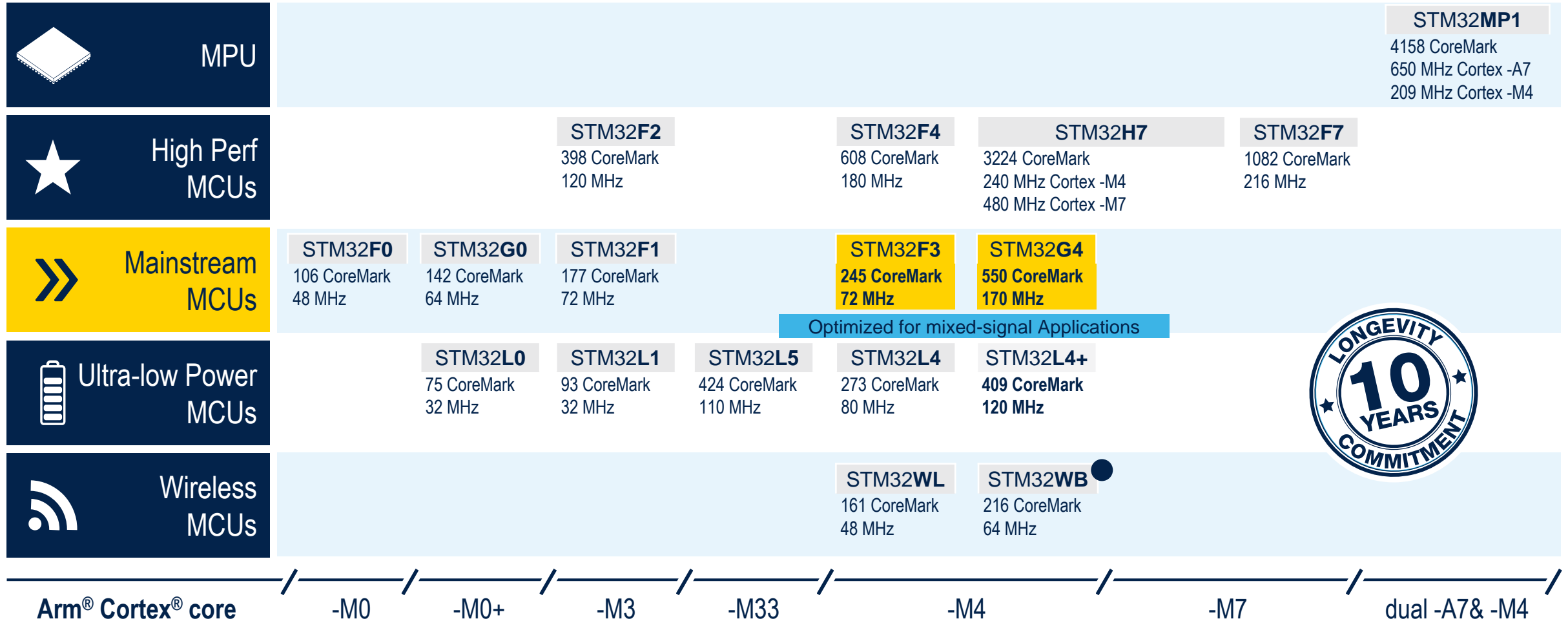

● Cortex-M0+ Radio co-processor

STM32G4 series

Ideal for applications requiring an MCU that offers advanced and rich analog peripherals



STM32G4

- Control applications (Motor Control...)
- Industrial equipment
- Instrumentation and Measurement
- Digital Power
 - Digital SMPS (switch mode power supply)
 - PFC (power factor correction)

Reducing PCB size and BOM cost

System-on-Chip – All-in-one solution

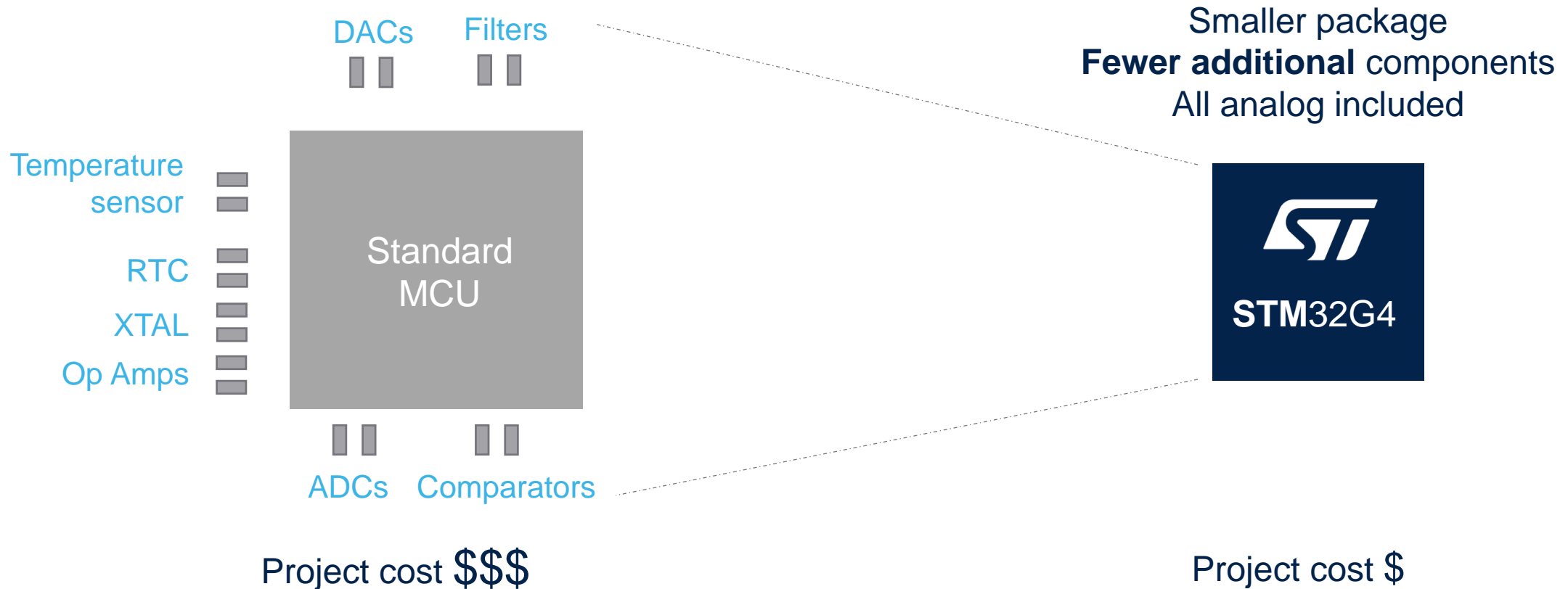

STM32G4 series – key messages

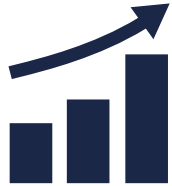

Performance

- Arm® Cortex®-M4 at 170 MHz
- 213 DMIPS and 550 CoreMark® results
- Better dynamic power consumption (163µA/MHz)
- ART Accelerator™ (dynamic cache)
- Mathematical accelerators
- CCM-SRAM Routine Booster (static cache)

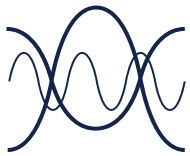

Rich Integrated Analog and Digital

- Op-Amps (Built-in gain), DACs, Comparators
- 12-bit ADCs 4MSPS with hardware oversampling
- CAN-FD (flexible data rate – 8 MSPS bit rate)
- High resolution timer (184 ps)
- USB type-C Power Delivery 3.0
- 1% RC accuracy [-5°..90°C], 2% full T° range



Safety and security focus

- Dual Bank Flash with ECC (error code correction)
- Securable Memory Area
- Hardware encryption AES-256
- SIL, Class-B
- SRAM with Parity bit

} Secure Live Upgrade

} Functional safety design packages

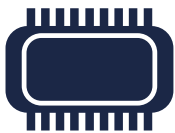

Complete portfolio

- Complements existing STM32F3 Series portfolio
- From -40°C up to 85 or 125°C devices
- From 32- up to 128-pin
- From 32 KB to 512 KB Flash

Greater performance

Pure 170 MHz CPU performance (Arm® Cortex®-M4) with three accelerators

Code execution performance

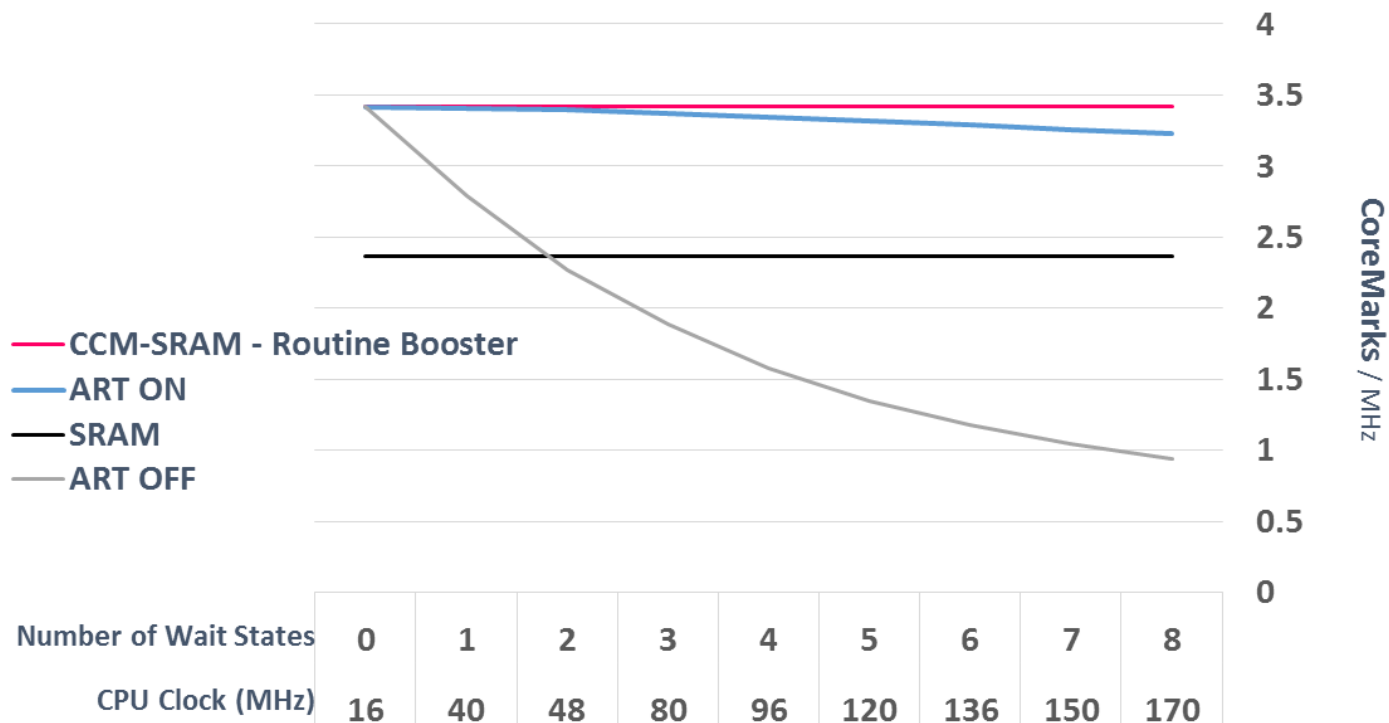

Arm Cortex-M4 with **FPU**

Up to 170 MHz CPU frequency

Up to 213 DMIPS and 550 CoreMark® results

3 different HW accelerators:

- **ART accelerator** (~dynamic cache) → Full code acceleration (average)
- **Routine Booster CCM-SRAM** (~static cache) → determinism preserved
- **Mathematical** (Cordic + FMAC) 



Mathematical accelerators

Function acceleration and CPU offload

1. Cordic (Trigo)

- Very helpful for Field Oriented Motor Control method (FOC)

- Vector rotation (polar to rectangular): Sin, Cos
- Vector translation (rectangular to polar): Atan2, Modulus
- Sinh, Cosh, Exp
- Atan, Atanh
- Square root
- Ln

2. Filter Math ACcelerator (FMAC)

- Can be used to create
 - 3p3z Compensator (\rightarrow Digital power)
 - Sigma Delta modulator
 - Noise Shaper

FIR filter

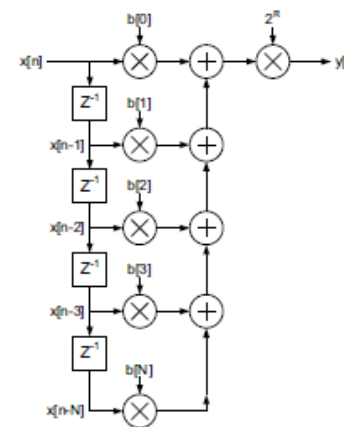

IIR filter

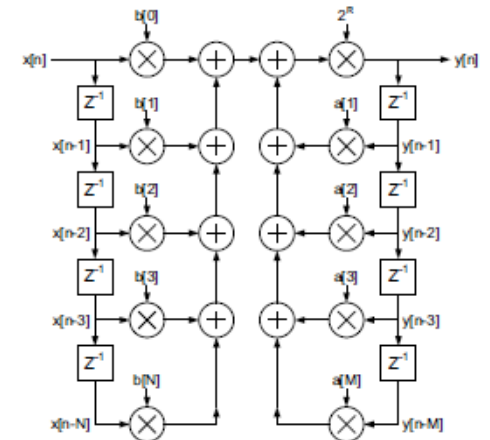

Rich, advanced analog

Mixed-signal SoC for wide variety of applications

ADC (up to 5)	Values
Topology	SAR 12-bit + HW oversampling → 16-bit
Sampling rate	Up to 4 Msps
Input	Single-ended and differential
Offset and Gain compensation	Auto calibration to reduce gain and offset

DAC (up to 7)	Values
Sampling rate	15 Msps (internal) 1 Msps (from buffered output)
Settling time	16 ns

Op-Amp (up to 6)	Values
GBW	13 MHz
Slew rate	45 V/μs
Offset	3 mV over full T° range 1.5 mV @ 25°C
PGA Gain (accuracy)	2, 4, 8, 16, -1, -3, -7, -15 (1%) 32, 64, -31, -63 (2%)

Comparator (up to 7)	Values
Power supply	1.62 .. 3.6 V
Propagation delay	16.7 ns
Offset	-6 .. +2 mV
Hysteresis	8 steps: 0, 9, 18, 27, 36, 45, 54, 63 mV

Shaped for control

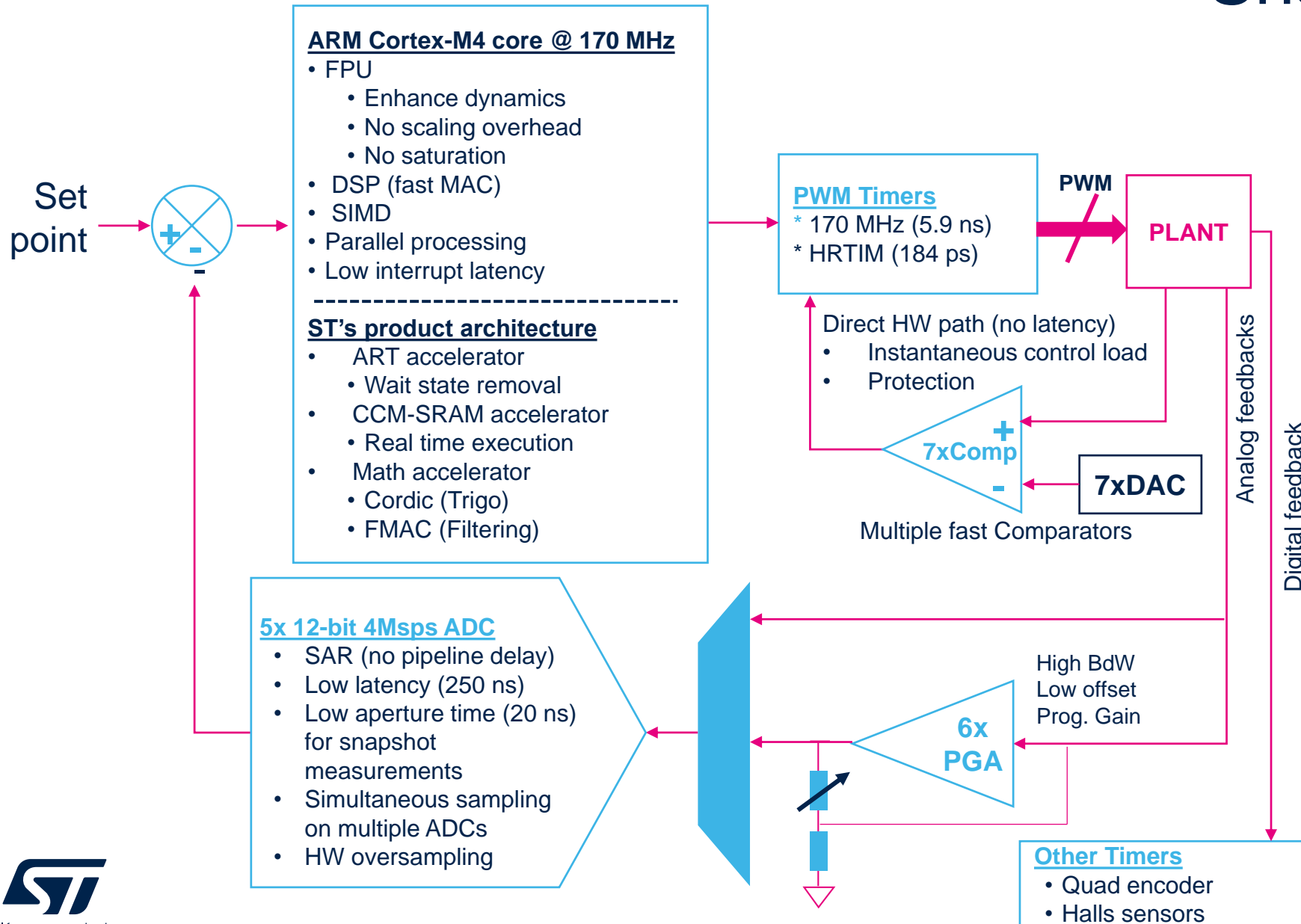

Easy use of the Analog and Digital resources thanks to high peripherals interconnect and flexible bus matrix

Key features for targeted applications

Motor Control

Home appliances, E-bikes, Air Conditioning

- Fast CPU 170MHz
- Mathematical accelerator (Cordic)
- Advanced Motor Control timers
- Fast comparators
- 4Mps ADC-12bit + HW oversampling
- Op-Amp with built-in gain (PGA)
- DAC-12bit
- 1% RC accuracy (UART communication w/o external Xtal)



High-End Consumer

Rechargeable devices, drones, toys

- Low-thickness, small form-factor
- Low consumption in run mode ~ 160 μ A/MHz
- Embedded analog
- SAI (Sound Audio Interface)
- USB type-C Power Delivery 3.0



Industrial devices Measurements

Industrial equipment

- Fast CPU 170MHz
- Mathematical accelerator (Cordic)
- High temperature 125°C
- CAN FD support
- SPI, USART, I²C
- Advanced timers
- Real Time Clock with backup registers
- Dual bank flash for live upgrade
- AES & security



Digital Power

Servers, Telecom, EV Charging station

- Fast CPU 170 MHz
- Mathematical accelerator (Filtering)
- 12ch High Resolution timer (184ps)
- 4Mps ADC-12bit + HW oversampling
- Fast comparators (17ns)
- Embedded analog
- Dual bank flash for **live** upgrade
- AES & security
- FMAC for 3p3z compensation



Ease digital power conversion

Enhance your digital power solutions using the STM32G4 full features High Resolution Timer (HRTIM)

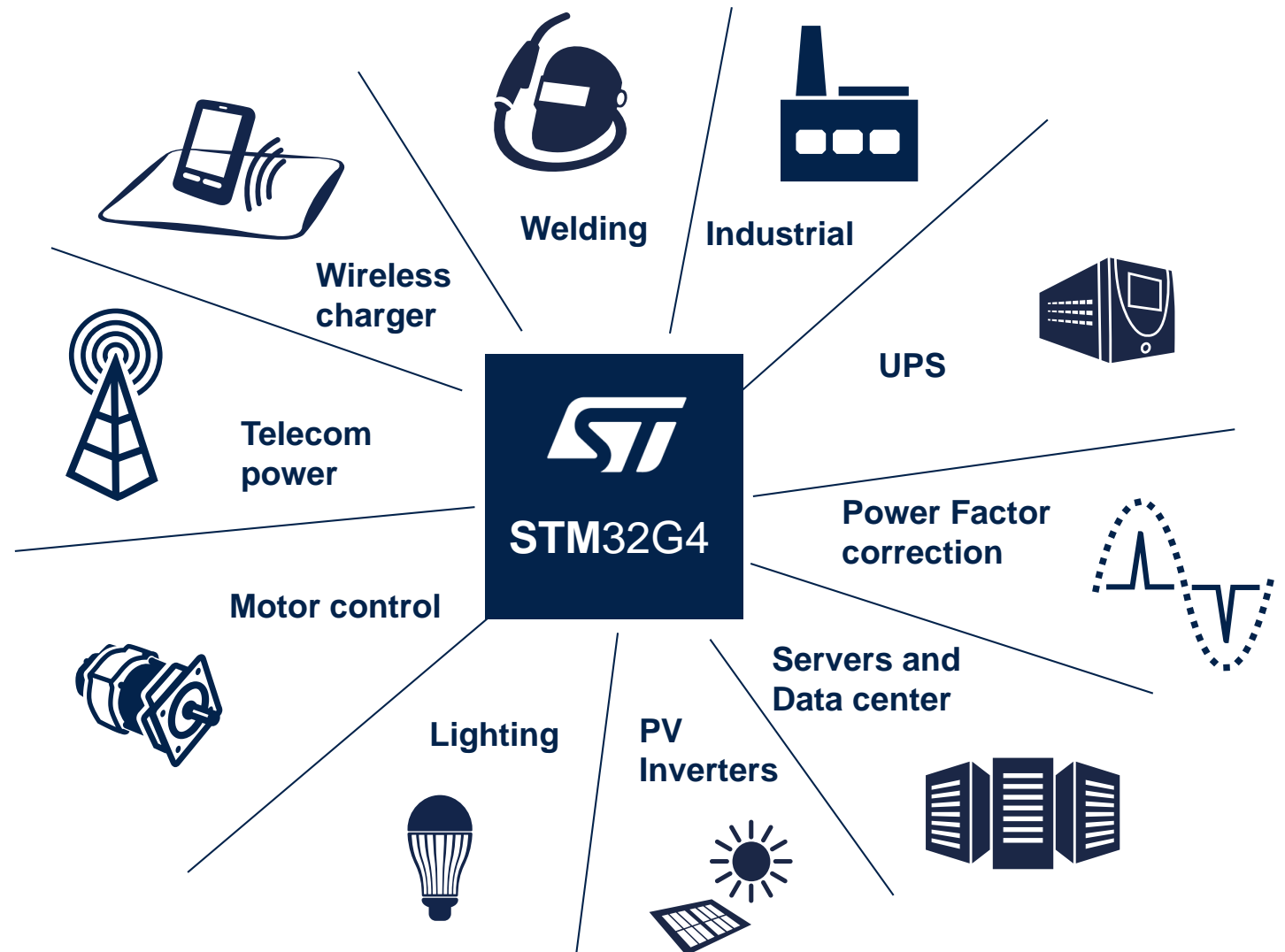

HRTimer – not only high resolution...

High resolution PWM

- 12 channels with 184ps resolution on frequency and duty cycle
- 184ps is equivalent to 5.4GHz timer clock

Flexible PWM generation

- 7x independent time base to create various shape of PWM
- 6x complementary pair PWM outputs
- Up to 32 set/reset transition per PWM period thx to the built-in crossbar
- Master/Slave configuration for multi phase converter

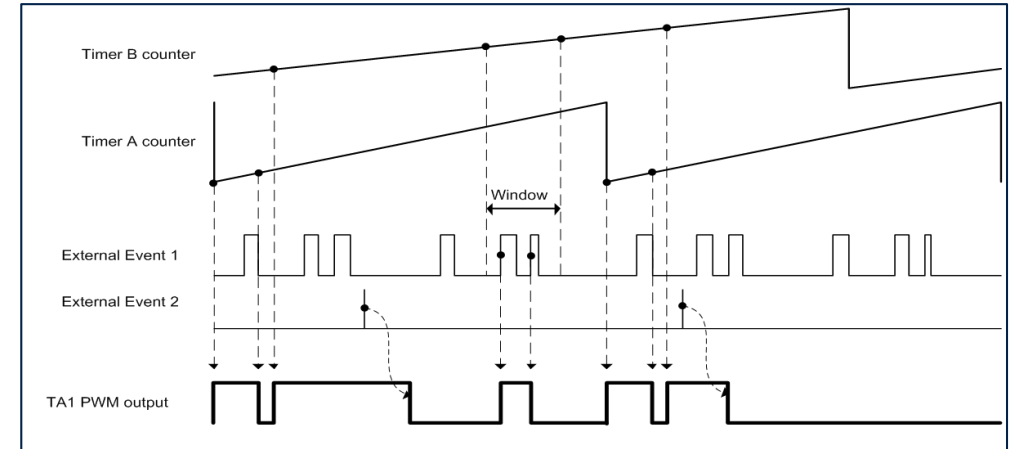

Multiple Event handler

- 6x Digital and Analog fault input
- 10x Events cycle to cycle current control or PWM restart (constant Ton/Toff)
- Blanking, windowing and digital filter

12 independent channels

- Any topology supported from 1x 12 PWM (triple interleaved LLC (servers application) up to 12x1 PWM (multiple independent buck converters (lighting))

Greater security

Integrated security features, ready for tomorrow's needs

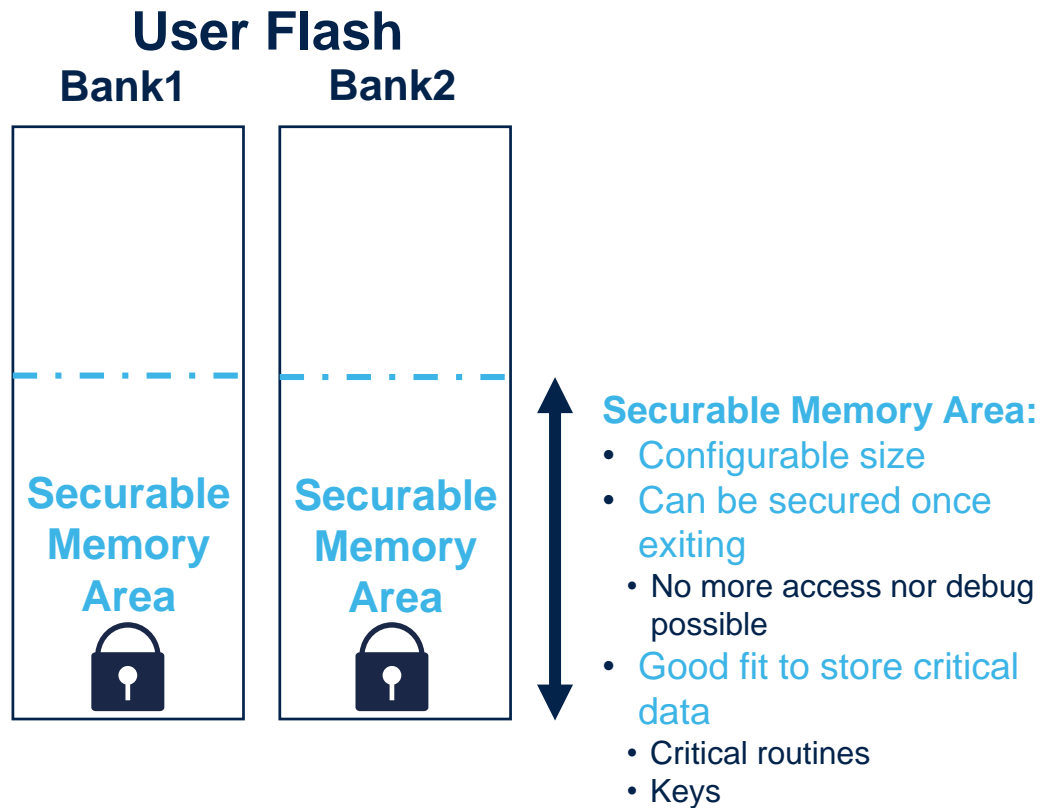

	Securable user memory	AES TRNG	PCROP	MPU	Readout protection	CRC	Write Protection
Secure firmware install (SFI)	●	●			●		
Secure Firmware upgrade (SFU)	●	●			●		●
Mutual Distrustful			●				
Firmware IP protection			●				
Secret key storage	●				●		
Secured communication		●				●	
Authentication	●	●			●		
Task cloisoning				●			

Dynamic efficiency modes

When Mainstream MCU Series meets low-power requirements

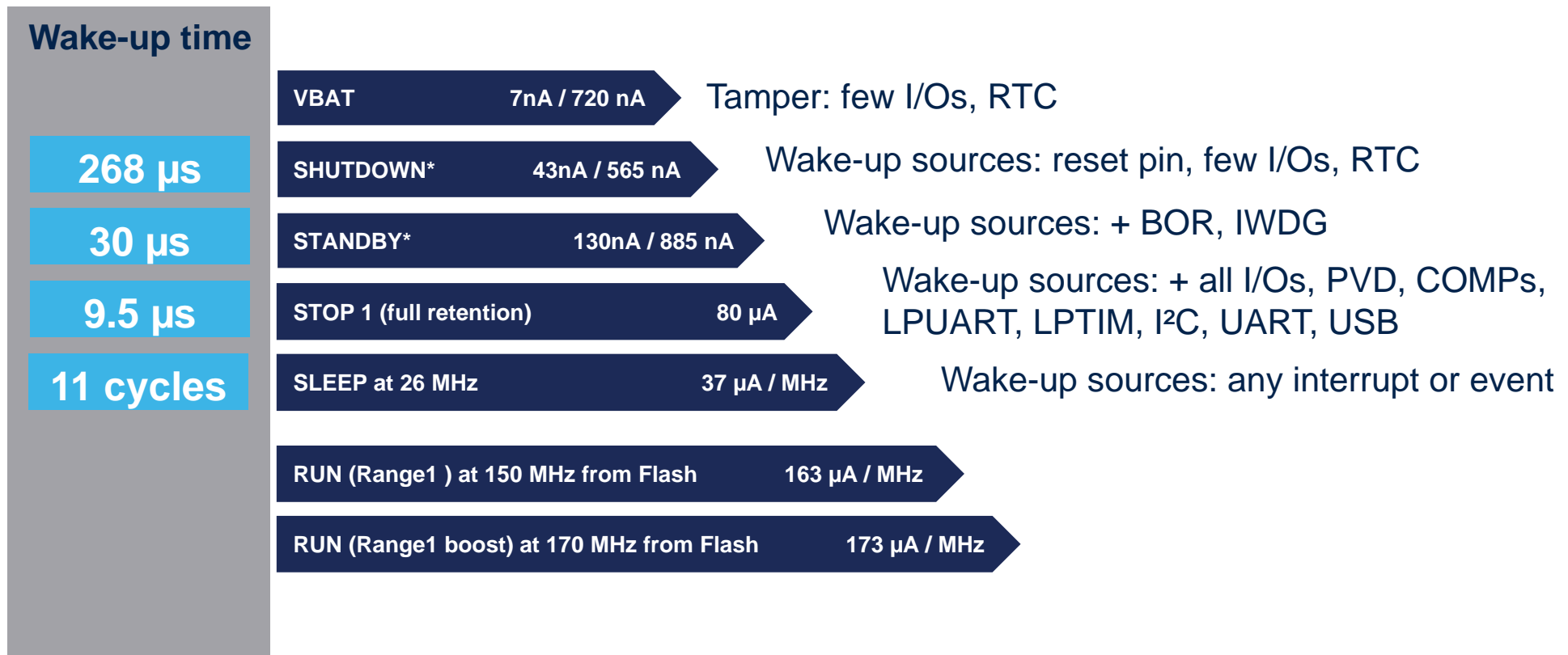

Conditions: 25°C, $V_{DD} = 3V$

Note : * without RTC / with RTC

STM32G4 products lines

General Purpose

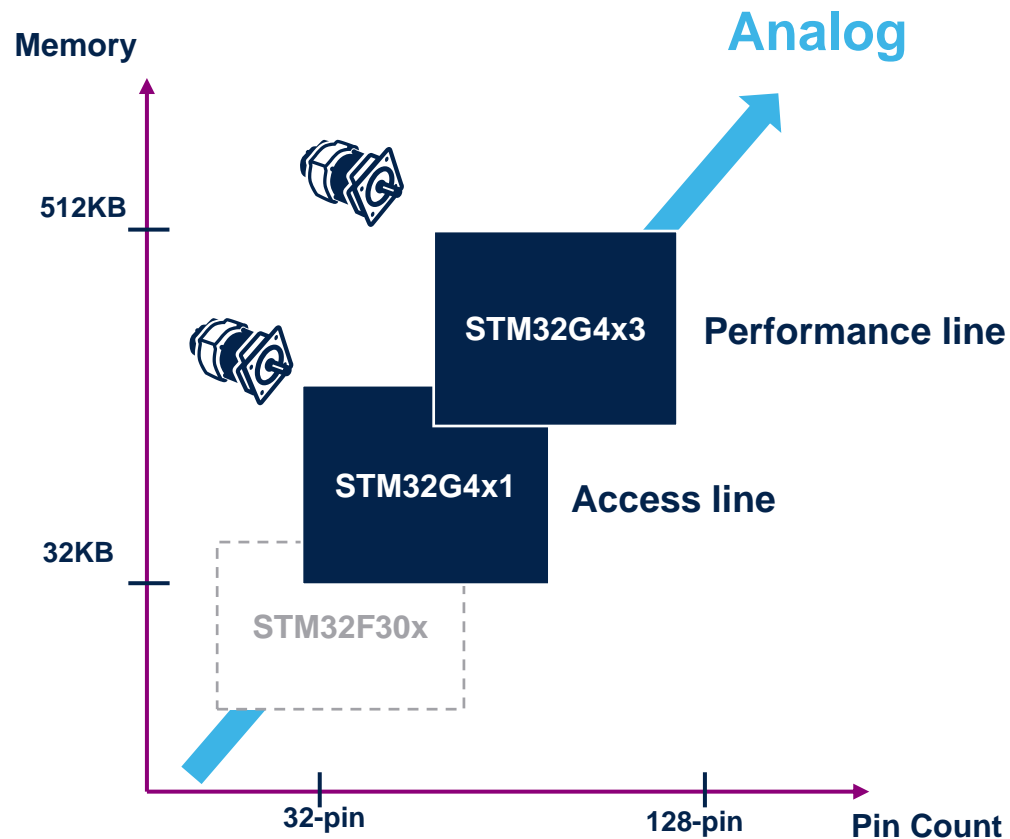

Application Specific

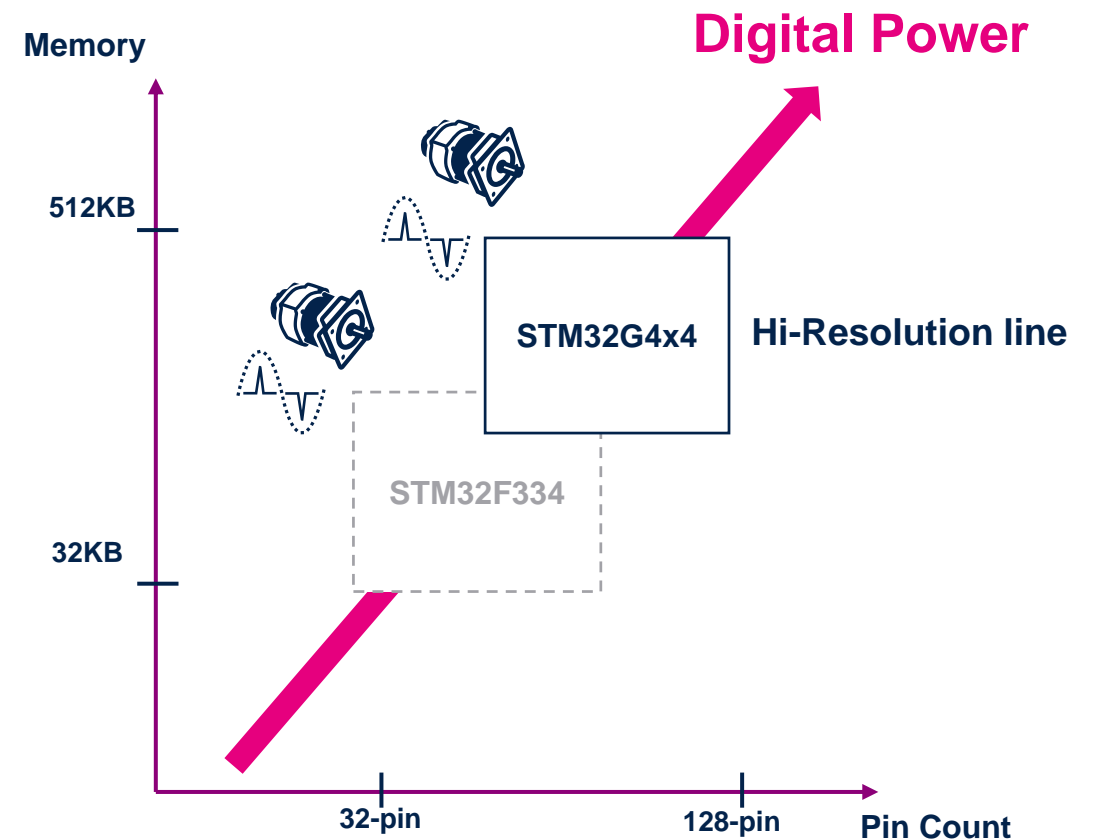

Extensive & innovative peripheral set

No compromise on what matters

Unit parameters	STM32G474 Hi-Resolution line	STM32G473 Performance line	STM32G431 Access line
Core, frequency	Arm Cortex-M4, 170 MHz		
Flash (max)	512 Kbytes (2x256 KB dual bank)		128 Kbytes single bank
RAM (up to)	96 Kbytes		22 Kbytes
CCM –SRAM (code-SRAM)	32 Kbytes		10 Kbytes
12-bit ADC SAR	4x 12-bit 4 MSPS		2x 12-bit 4 MSPS
Comparator	7		4
Opamp with 4 built-in gain values with 1% accuracy	6		3
12-bit DAC	7		4
Motor Control timer	3x (170 MHz)		2x (170 MHz)
CAN-FD	3x		1x
12 channel Hi-resolution Timer	1x	-	-
Power supply	1.72 to 3.6 V		

High Resolution and Performance lines [128KB .. 512KB]

- 32-bit Arm Cortex-M4 core with FPU
- ART + CCM-SRAM + Mathematic Accelerators
- Dual Bank Flash with ECC
- SRAM with Parity bit
- +/- 1% internal clock
- 1.72 to 3.6V power supply
- Up to 125°C



- High resolution timer
- 3x Advanced Motor Control timers
- Rich Advanced Analog
- 3x CAN Flexible Data rate
- USB-C Power Delivery3.0
- Advanced Security and Safety features
- Robustness: highest level 5 / FTB/ESD - IEC 61000-4-4

Access line [32KB .. 128KB] and up to 512KB in H1-2020

- **32-bit Arm Cortex-M4 core with FPU**
- **ART + CCM-SRAM + Mathematic Accelerators**
- **Single Bank Flash with ECC**
- **SRAM with Parity bit**
- **+/- 1% internal clock**
- **1.72 to 3.6V power supply**
- **Up to 125°C**

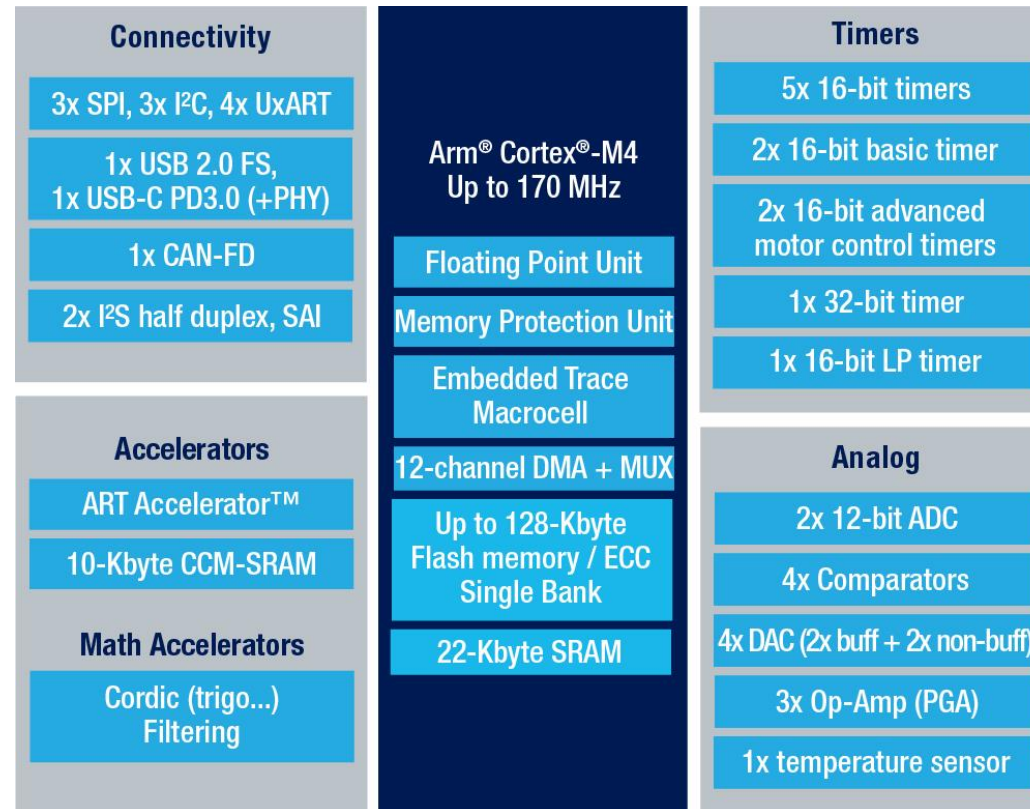

- **2x Advanced Motor Control timers**
- **Rich Advanced Analog**
- **CAN Flexible Data rate**
- **USB-C Power Delivery3.0**
- **Advanced Security and Safety features**
- **Robustness: highest level 5 / FTB/ESD - IEC 61000-4-4**

STM32G4 portfolio

Flash memory / RAM size (bytes)



Legend:

Crypto AES-256

Available in H1 2020

Broad portfolio

Portfolio extended to support budget applications efficiently

More memory and pin counts

Flash memory (bytes)	32-pin LQFP QFN	48-pin LQFP QFN	64-pin LQFP BGA WLCSP	80-pin LQFP WLCSP	100-pin LQFP BGA	121-pin BGA	128-pin LQFP
512 K		✓	✓	✓	✓	✓	✓
256 K		✓	✓	✓	✓	✓	✓
128 K	✓	✓	✓	✓	✓	✓	✓
64 K	✓	✓	✓	✓	✓		
32 K	✓	✓	✓	✓	✓		

More packages

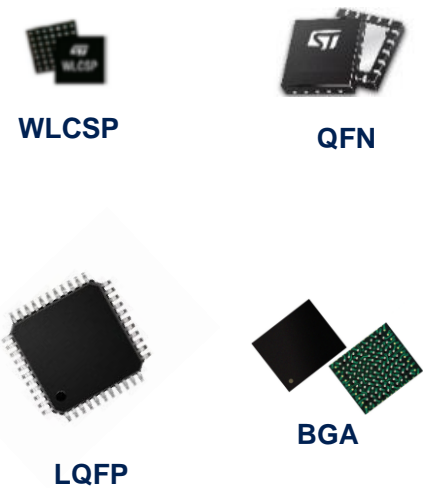

Note: new packages in STM32 portfolio

STM32G4 hardware solutions

Accelerate evaluation, prototyping and design

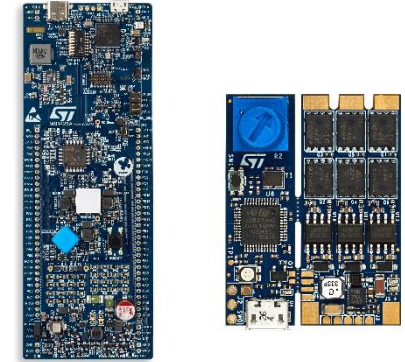
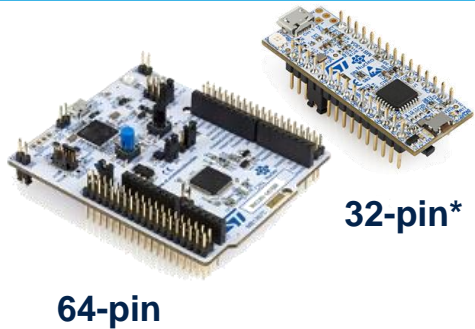

STM32 Nucleo

Flexible prototyping

- NUCLEO-G431RB
- NUCLEO-G474RE
- NUCLEO-G431KB*

Evaluation boards

Full feature STM32G4 evaluation

- STM32G484E-EVAL
- STM32G474E-EVAL
- STM32G474E-EVAL1

Motor Control Pack

Full feature for Motor Control and Analog

- P-NUCLEO-IHM03

Discovery kits

Key feature prototyping

- B-G474E-DPOW1*
- B-G431B-ESC1*

STM32G4 software tools

Complete support of Arm Cortex-M ecosystem

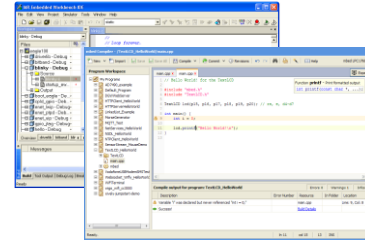
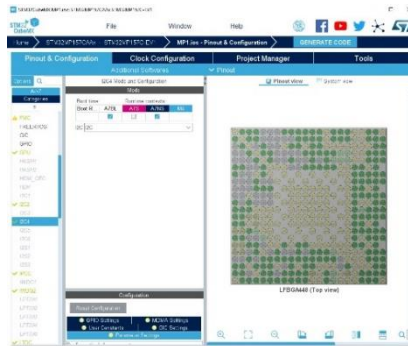

All-in-one STM32 programming tool
Multi-mode, user-friendly



STM32CubeMX

STM32CubeMX

- Configure and generate Code
- Conflicts solver

IDEs Compile and Debug

Flexible Solutions

- Partners IDE, like IAR and Keil
- Free IDE based on Eclipse, like STM32CubeIDE

STM32 Programming Tool

STM32CubeProgrammer

- Flash and/or system memory
- GUI or command line interface

Dedicated ecosystems

Motor Control

- **Complete ecosystem** (HW boards, SW Development Kit (SDK), docs and trainings)
 - **X-CUBE-MCSDK** (v5.4)
 - Motor Control FW library based on STM32Cube HAL and LL
 - Motor control workbench: Graphical configurator of the motor control library linked with STM32CubeMx
 - **P-NUCLEO-IHM03**: Motor Control Nucleo pack
 - NUCLEO-G431RB Nucleo-64
 - X-NUCLEO-IHM16M1 motor driver expansion board
 - Low Voltage motor
- **State of the art algorithms** (FOC, 6-step, sensorless...)
- **Motor Profiler**: Plug and spin your motor within less than one minute

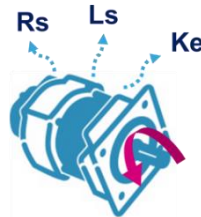

Digital Power

- **Complete ecosystem** (HW boards, FW examples, SW tools, docs and trainings)
- **Dedicated HRTIM Cook Book - AN4539**: How to operate the Hi-Resolution timer in different topology
- **Digital Power training** (PSU and PFC) – based on STM32 G4 series – done in collaboration with Biricha (from Q4 2019)



STM32G4 series – takeaways

Analog-rich MCUs for mixed-signal applications

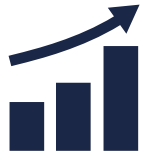

Performance

170 MHz Cortex-M4 coupled with three accelerators

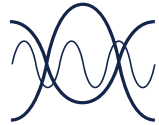

Rich and Advanced Integrated Analog

ADC, DAC, opamp, comparator



Safety and security focus

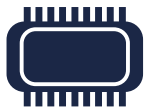

Large portfolio available from NOW!

32..512KB Flash memory

32..128-pin packages

Releasing your creativity



[/STM32](#)



[@ST_World](#)



[community.st.com](#)



[www.st.com/STM32G4](#)



life.augmented

Thank you

© STMicroelectronics - All rights reserved.

The STMicroelectronics corporate logo is a registered trademark of the STMicroelectronics group of companies. All other names are the property of their respective owners.



life.augmented