

Preface

UCTRONICS is an open source hardware company dedicated in designing and manufacturing PC boards for the makers and industrial market, especially for the Arduino and Raspberry Pi alike open source ecosystem. Our Products line covers breakout boards, Arduino kits, Raspberry Pi kits, Robots Kits and etc. In addition, we have excellent hardware and software engineer team with more than 10 years experience on embedded system. We can provide customized design and manufacture services for customers who want turnkey solution and make their products unique and standard out.

About Tutorial

This tutorial is written for Arduino beginners. Colorful pages, rich pictures and detail instruction will help beginners to master the basic information about how to use Arduino controller board, sensors and components. In addition, the tutorial includes experiments with code which will teach beginners how to do programming. (Lesson1-9 for KB0001 Primary Starter Kit for Arduino, lesson1-21 for KB0002 Advanced Starter Kit for Arduino, lesson1-33 for KB0003 Ultimate Starter Kit for Arduino).

Moreover, it is available to get both connection schematic and wiring diagram to help beginners get a clearly sense of wiring.

You can also get a PDF version tutorial from the following link:

https://www.uctronics.com/Amazon/Ultimate_Starter_Kit_for_Arduino.pdf

If any questions, please feel free to contact us by the following ways:

Website: <http://www.uctronics.com>

Email: support@uctronics.com

Tel: +86 025 84271192

NOTE:

1. The UNO and MEGA boards are pin compatible on the left part of the diagrams.
2. Before learning the following courses, please check the following link to download the ZIP file of library and code to your local folder.

https://github.com/UCTRONICS/uctronics_arduino_kits.git













Content






| | |
|--|----|
| Component List | 4 |
| Prerequisite | 9 |
| Install Arduino IDE | 9 |
| Add Libraries and Open Serial Monitor | 12 |
| Lessons | 15 |
| Lesson 1 Blink and Breathing LED | 15 |
| Lesson 2 LED Flowing Lights | 18 |
| Lesson 3 Digital Inputs-Switches | 20 |
| Lesson 4 Controlling a RGB LED by PWM | 21 |
| Lesson 5 Active Buzzer | 23 |
| Lesson 6 Playing Music | 25 |
| Lesson 7 Tilt Ball Switch | 27 |
| Lesson 8 7-segment display | 29 |
| Lesson 9 Photoresistor | 31 |
| Lesson 10 Relay | 33 |
| Lesson 11 4-Bit 7-Segment Display | 35 |
| Lesson 12 Servo Motor | 37 |
| Lesson 13 DC Motor | 38 |
| Lesson 14 Stepper Motor | 40 |
| Lesson 15 Intrusion Detection by PIR | 42 |
| Lesson 16 1602 LCD Display | 44 |
| Lesson 17 Thermometer | 46 |
| Lesson 18 Temperature & humidity sensor DHT-11 | 48 |












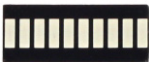
| | | |
|-----------|--|----|
| Lesson 19 | Joystick Module | 50 |
| Lesson 20 | Ultrasonic Sensor Module | 52 |
| Lesson 21 | IR Remote Controller..... | 54 |
| Lesson 22 | LED bar graph display..... | 56 |
| Lesson 23 | 4*4 Matrix Keyboard | 58 |
| Lesson 24 | Real Time Clock Module | 60 |
| Lesson 25 | Water Level Detection Sensor Module..... | 62 |
| Lesson 26 | Sound Sensor Module | 64 |
| Lesson 27 | MAX7219 LED Dot Matrix Module..... | 66 |
| Lesson 28 | Frequency Meter | 67 |
| Lesson 29 | MPU-6050 Module..... | 69 |
| Lesson 30 | Controlling Stepper Motor with Remote | 71 |
| Lesson 31 | Controlling Stepper Motor with Rotary Encoder..... | 72 |
| Lesson 32 | ESP8266..... | 73 |
| Lesson 33 | Building a Smart Home System | 78 |





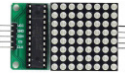






Component List

| No. | Name | Picture | Qty |
|-----|--|---|-----|
| 1 | UNO R3 / MEGA2560 R3 |  | 1 |
| 2 | UNO R3 / MEGA 2560 R3 Proto Shield V3 |  | 1 |
| 3 | 400 Tie / 830 Tie Point Breadboard |  | 1 |
| 4 | 65 Male to Male Jumper Wire |  | 1 |
| 5 | 15cm Male to Female DuPont Wire |  | 20 |
| 6 | USB Cable |  | 1 |
| 7 | 9V Battery Clip |  | 1 |
| 8 | 9V 1A Power Supply |  | 1 |
| 9 | 220Ω Resistor |  | 20 |
| 10 | 1KΩ Resistor |  | 20 |
| 11 | 10KΩ Resistor |  | 10 |

| No. | Name | Picture | Qty |
|-----|------------------------------------|---|-----|
| 12 | SS12D00G3 Switch |  | 2 |
| 13 | Power Supply Module for Breadboard |  | 1 |
| 14 | 5mm Green LED |  | 4 |
| 15 | 5mm Yellow LED |  | 4 |
| 16 | 5mm Blue LED |  | 4 |
| 17 | 5mm Red LED |  | 8 |
| 18 | 74HC595 IC |  | 2 |
| 19 | 6x6x5mm Button |  | 8 |
| 20 | 5mm RGB LED |  | 1 |
| 21 | 5V Active Buzzer |  | 1 |
| 22 | 16R Passive Buzzer |  | 1 |
| 23 | S8050 NPN Transistor |  | 2 |

| No. | Name | Picture | Qty |
|-----|--------------------------|---|-----|
| 24 | S8550 PNP Transistor |  | 2 |
| 25 | SW520D Tilt Switch |  | 2 |
| 26 | 7-Segment Display |  | 1 |
| 27 | GL5528 Photo Resistor |  | 2 |
| 28 | 5V Relay Module |  | 1 |
| 29 | 1N4007 Diode |  | 4 |
| 30 | 1N4148 Diode |  | 4 |
| 31 | 4-bit 7 Segment LED |  | 1 |
| 32 | SG90 9g Servo |  | 1 |
| 33 | DC Motor |  | 1 |
| 34 | L9110 DC Motor Driver IC |  | 1 |
| 35 | Fan |  | 1 |

| No. | Name | Picture | Qty |
|-----|------------------------------|---|-----|
| 36 | Stepper Motor |  | 1 |
| 37 | ULN2003 Stepper Motor Driver |  | 1 |
| 38 | PIR Motion Sensor |  | 1 |
| 39 | 1602 LCD |  | 1 |
| 40 | 10K Potentiometer |  | 2 |
| 41 | 502 5K Thermistor |  | 1 |
| 42 | DHT11 Temp & Humi Sensor |  | 1 |
| 43 | Joystick Module |  | 1 |
| 44 | HC-SR04 Ultrasonic Sensor |  | 1 |
| 45 | HX1838 IR Receiver |  | 1 |
| 46 | 21 keys Remote Controller |  | 1 |
| 47 | 10 Segment LED |  | 1 |

| No. | Name | Picture | Qty |
|-----|-------------------------------|---|-----|
| 48 | 4x4 Matrix Keyboard |  | 1 |
| 49 | RTC Module |  | 1 |
| 50 | Water Level Sensor |  | 1 |
| 51 | Sound Sensor Module |  | 1 |
| 52 | MAX7219 8x8 LED Module |  | 1 |
| 53 | NE555 Timer |  | 1 |
| 54 | Ceramic Capacitor (104 100nf) |  | 10 |
| 55 | 10uF Electrolytic Capacitor |  | 2 |
| 56 | MPU-6050 Module |  | 1 |
| 57 | Rotary Encoder Module |  | 1 |
| 58 | ESP8266 Module |  | 1 |

Prerequisite

Install Arduino IDE

The Arduino software IDE Integrated Development Environment (IDE) allows you to write programs and upload them to your board. Here, you will learn how to set up the software to program your board.

Step 1: Go to the Arduino download page: <https://www.arduino.cc/en/Main/Software> shown in Figure 1.

The version available from official website is the latest version, the figures in this tutorial might be slightly different from yours.

Select one Arduino IDE according to your operating system download. **(Take Windows as an example)** There are two versions of Arduino for Windows: Installer and ZIP file. Click “Windows Installer” .

Download the Arduino IDE

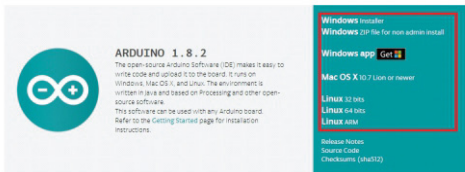


Figure 1 Arduino IDE Download Page

Step 2: Press the button “JUST DOWNLOAD” to download the software shown in Figure 2

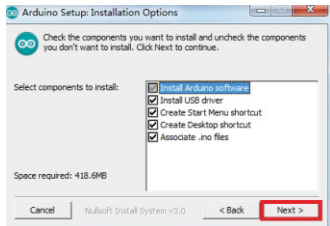
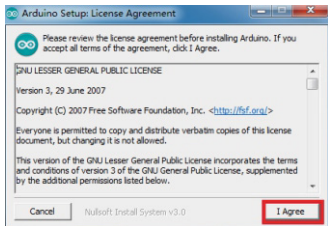
Support the Arduino Software

Consider supporting the Arduino Software by contributing to its development. (US tax payers, please note this contribution is not tax deductible). [Learn more on how your contribution will be used.](#)

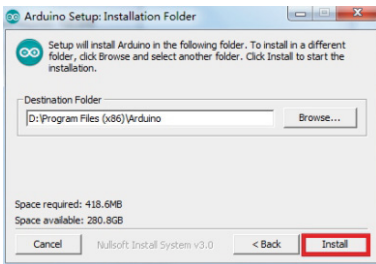


Figure 2 Download

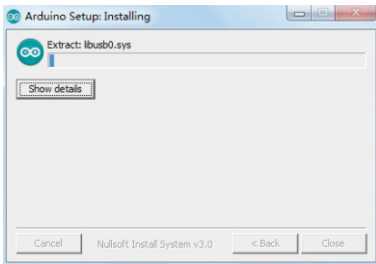
Step 3: Double click the "windows.exe" file to the following dialog box and then click "I Agree" and then click "Next".



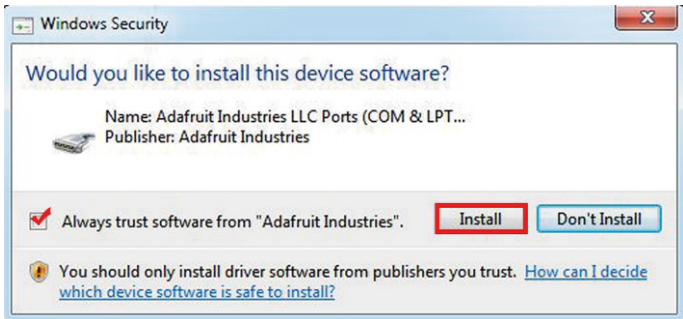
Step 4: Click "Browse" to choose the installation path or enter a directory at the Destination Folder. Click "Install" to initiate installation.



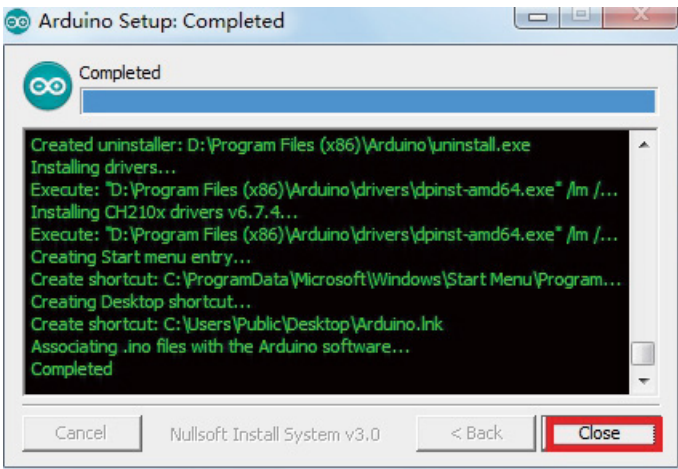
Step 5: After installation ended, click "Close" to finish.



Step 6: When the dialog box pop up like Figure 2 shown, Select Always trust software for "Adafruit Industries" and click "Install".



Step 7: When the installation is done, click "Close". Then an Arduino icon will appear on the desktop:



Add Libraries and Open Serial Monitor

Add Libraries

Libraries are a collection of code that makes it easy for you to connect to a sensor, display, module, etc. For example, the built-in LiquidCrystal library makes it easy to talk to character LCD displays. Libraries provide extra functionality for use in sketches, e.g. working with hardware or manipulating data. There are hundreds of additional libraries available on the Internet for download. To use the additional libraries, you will need to install them.

To install the library, first exit the Arduino IDE. Then unzip the ZIP file of the library (download from the GitHub link). Copy the library file into your libraries folder (This PC\ Documents\ Arduino\ libraries\). Next, restart the Arduino IDE, you will find the library appears in the Sketch->include library shown in Figure 3.

There may be more files excluding the .cpp and .h files in the library folder, make sure they're all there. The library won't work if you put the .cpp and .h files directly into the libraries folder or if they're nested in an extra folder.

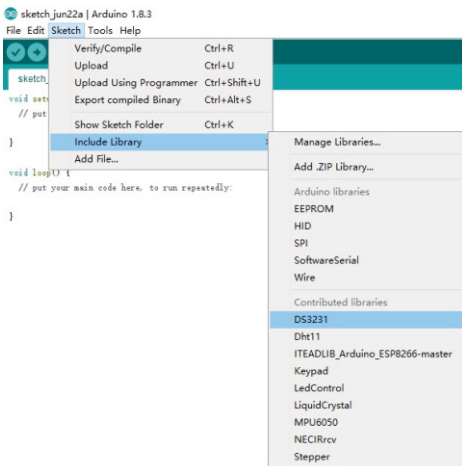


Figure 3 Include library

Compile and download program.

Click the tools to select the correct board and the port you're using as shown in figure 4 and figure 5.

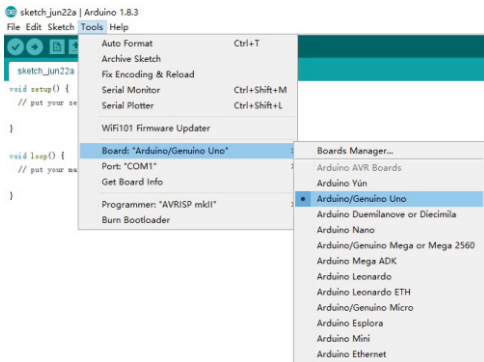


Figure 4 Select Board

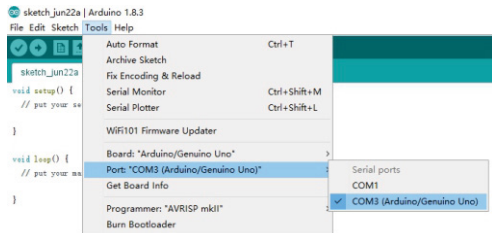


Figure 5 Select Port

Click the verify icon to compile and make sure your program is correct and then click the upload icon to download the program shown in Figure 6 and Figure 7.



Figure 6 Verify sketch



Figure 7 Download sketch

Open Serial Monitor

The Serial Monitor is a separate pop-up window that acts as a separate terminal that

communicates by receiving and sending serial data. The serial monitor is the 'tether' between the computer and your UNO. It lets you send and receive text messages, handy for debugging and also controlling the UNO from a keyboard. See the icon on the upper right of Figure 8. You just need to click the serial monitor icon to open it.

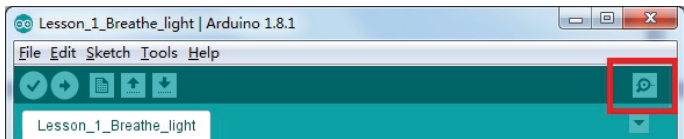
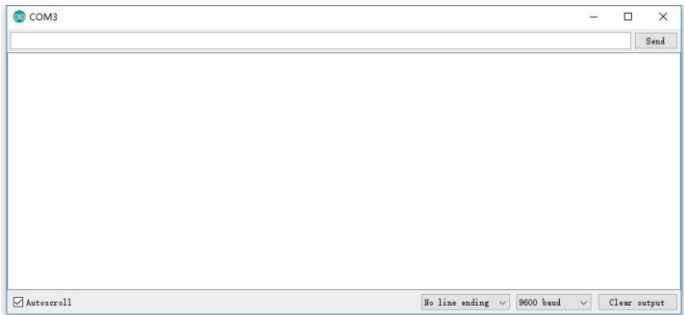


Figure 8 Serial monitor

To send data to the board, enter text and click on the "send" button or press enter. Choose the baud rate from the drop-down that matches the rate passed to `Serial.begin` in your sketch.



Which port selected to open in the serial monitor is the same as the port for uploading Arduino code. Go to Tools -> Serial Port, and select the correct port.

How to start a lesson

Step 1 Add the library (This step only needs to do once, if you have already installed, please skip this step.)

Step 2 Find and double click the file of lesson code, then you will see the IDE dialog box.

Step 3 Connect the components according to the connection schematic and wiring diagram. Then connect your UNO board or MEGA2560 to PC via the USB cable.

Step 4 Compile and download the program. Then you will see the result.

Lessons

Lesson 1 Blink and Breathing LED

Overview

In this project, you will learn the simplest thing you can do with an Arduino and see physical world by blinking the on-board LED and without doing any programming.

Second step, you will learn how to use the PWM square-wave signal to control the external LED as a breathing lamp which gradually becomes brighter and then gradually becomes dark.

Components required

| Name | Qty | Name | Qty |
|---------------------|-----|---------------|-----|
| UNO R3 or MEGA 2560 | 1 | 220Ω Resistor | 1 |
| 5mm Red LED | 1 | DuPont Wire | 2 |

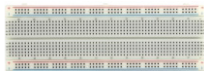
Component Introduction

The UNO R3 board has rows of connectors along both sides that are used to connect to different electronic devices and plug-in 'shields' that extends its capability.

It also has a single LED that you can control from your sketches. This LED is built onto the UNO R3 board and is often referred to as the 'L' LED as this is how it is labeled on the board. You may find that your UNO R3 board's 'L' LED already blinks when you connect it to a USB plug. This is because the boards are generally shipped with the 'Blink' sketch pre-installed.

Since the first experiment of blinking onboard LED is quite so easy without any programming, it just gives you an idea about how electronic device works. The next step we will try something interesting and more complex by connecting a breadboard and external LED to build a breathing lamp.

Breadboard is just a grid of holes in a plastic block. Inside are strips of metal that provide electrical connection between holes in the shorter rows. Pushing the legs of two different components into the same row joins them together electrically.



LED is the abbreviation of light emitting diode. The LED has two electrodes, a positive electrode and a negative electrode, it will light only when a forward current passes. Generally, the drive current for LED is 5-20mA. Therefore, it needs an extra resistor for current limitation

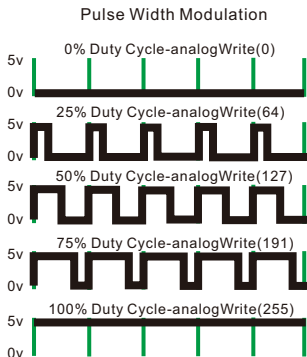
to protect the LED. Otherwise, it will burn out!

In the following connection schematic, you will see the picture shown "+" "-"

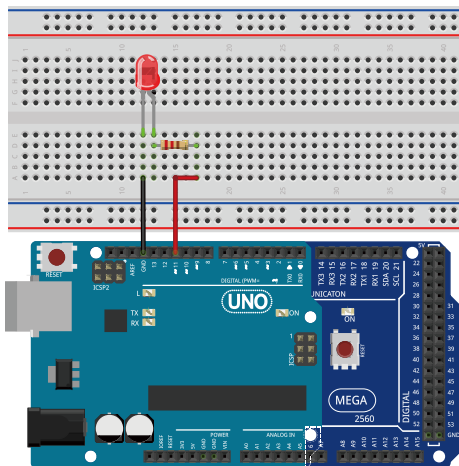


In the wiring diagram, the longer pin (the curved pin) represents anode, the opposite one is cathode.

In the first step experiment we blink the onboard LED by tuning it on and off, the brightness of LED can't be changed. So in the second step we will use PWM technique to adjust the brightness. Pulse Width Modulation, or PWM, is a technique for getting analog results with digital means. Digital control is used to create a square wave, a signal switched between on and off. This on-off pattern can simulate voltages in between full on (5 Volts) and off (0 Volts) by changing the portion of the time the signal spends on versus the time that the signal spends off. The duration of "on time" is called the pulse width. To get varying analog values, you change, or modulate, that pulse width. If you repeat this on-off pattern fast enough with an LED for example, the result is as if the signal is a steady voltage between 0 and 5v controlling the brightness of the LED. In the diagram below, the green lines represent regular time period. This duration or period is the inverse of the PWM frequency. In other words, with Arduino's PWM frequency at about 500Hz, the green lines would measure 2 milliseconds each. A call to analog Write () is on a scale of 0 - 255, such that analog Write (255) requests a 100% duty cycle (always on), and analog Write (127) is a 50% duty cycle (on half the time) for example.



Wiring Diagram



Result

LED is lit up and went out gradually like breathing.

Lesson 2 LED Flowing Lights

Overview

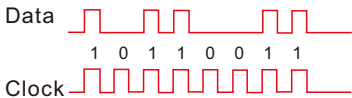
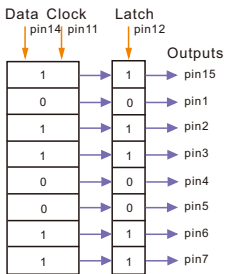
In this lesson, you will master how to use eight large red LEDs with an UNO or MEGA2560 board without using up 8 output pins.

Components required

| Name | Qty | Name | Qty |
|---------------------|-----|---------------|-----|
| UNO R3 or MEGA 2560 | 1 | 220Ω Resistor | 8 |
| LED | 8 | DuPont Wire | 17 |
| 74HC595 IC | 1 | Breadboard | 1 |

Component Introduction

The 74HC595 is an 8-stage serial shift register with a storage register and 3-state outputs. Each of which can either be a 1 or a 0. The shift register and storage register have separate clocks. To set each of these values on or off, we feed in the data using the pin 'Data' and 'Clock' of the chip.



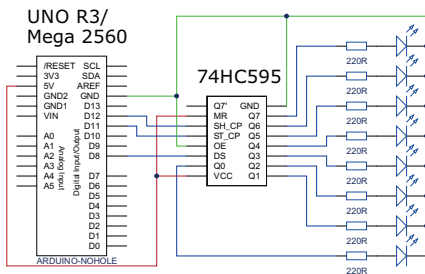
The clock pin is used to receive eight pulses. At each pulse, if the pin "data" is high, then a 1 gets pushed into the shift register; otherwise, a 0.

When all eight pulses have been received, enabling the pin of "Latch" copies those eight values to the latch register. This is necessary; otherwise, the wrong LEDs would flicker as the data is being loaded into the shift register.

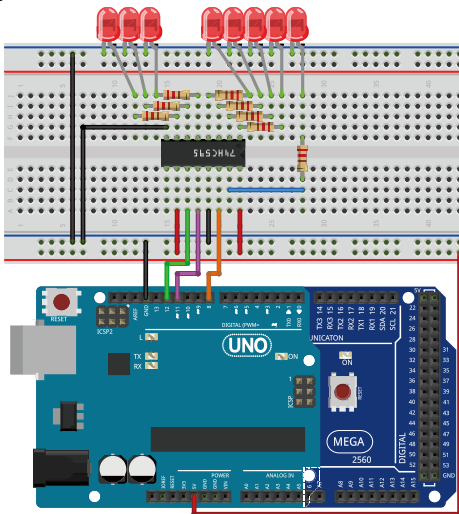
The chip also has an output enable pin (OE), which is used to enable or disable the outputs all at once. You could attach this to a PWM-capable pin of UNO and use 'analog Write' to

control the brightness of the LEDs. This pin is active low, so in this lesson we tie it to GND.

Connection Schematic



Wiring Diagram



Result

LEDs flash in turn.

Lesson 3 Digital Inputs-Switches

Overview

In this lesson, you will master how to use buttons with digital inputs to turn LED on and off.

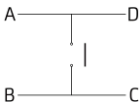
Components Required

| Name | Qty | Name | Qty |
|---------------------|-----|---------------|-----|
| UNO R3 or MEGA 2560 | 1 | 220Ω Resistor | 1 |
| 5mm Red LED | 1 | DuPont Wire | 7 |
| Push Switches | 2 | Breadboard | 1 |

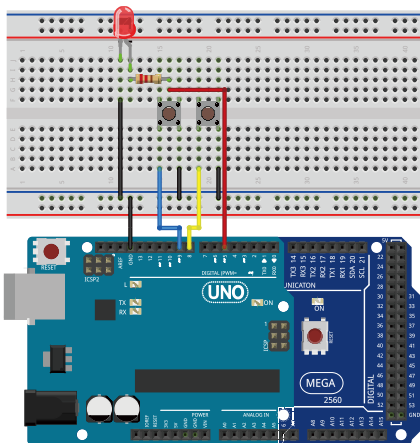
Component Introduction

The switch is a simple component. When you press a button or flip a lever, they A connect two contacts together so that electricity can flow through them.

Actually, there are only really two electrical connections. Inside the switch B and C are connected together as same as pins A and D.



Wiring Diagram



Result

Press the left button, the LED will be lit, and press the right button, LED will be extinguished.

Lesson 4 Controlling a RGB LED by PWM

Overview

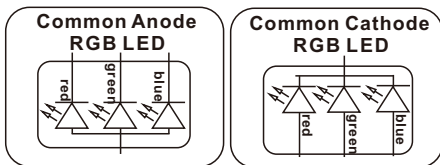
In this lesson, you will master how to program the UNO R3 or MEGA 2560 board for RGB LED control and make RGB LED emits a variety of colors.

Components Required

| Name | Qty | Name | Qty |
|---------------------|-----|-----------------------|-----|
| UNO R3 or MEGA 2560 | 1 | 220 Ω Resistor | 3 |
| RGB LED | 1 | DuPont Wire | 4 |
| Breadboard | 1 | | |

Component Introduction

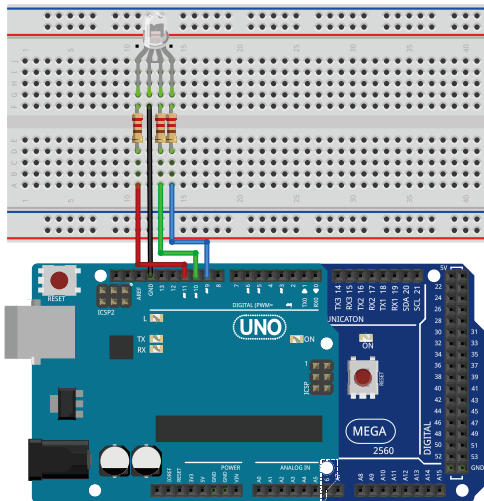
A RGB LED also known as Tri-color LED consists of three LEDs with a red, a green and a blue light. These three colored LEDs are capable of producing any color. It uses a four-wire connection with one common lead (anode or cathode). These LEDs can have either common anode or common cathode leads.



What we used in this experiment is the common anode RGB LED. The longest pin is the common anode of three LEDs. The pin is connected to the +5V pin from the Arduino, and the three remaining pins are connected to the Arduino's D9, D10, D11 pins through a current limiting resistor.

In this way, we can control the color of RGB LED by 3-channels PWM signal.

Wiring Diagram



Result

The RGB LED emit red, green, blue, yellow, white and purple light. Each color will last for 1s then change to another color in turns.

Lesson 5 Active Buzzer

Overview

In this lesson, you will learn how to generate a sound with an active buzzer.

Components Required

| Name | Qty | Name | Qty |
|---------------------|-----|------------------------|-----|
| UNO R3 or MEGA 2560 | 1 | 1K Ω Resistor | 1 |
| Active Buzzer | 1 | NPN Transistor (S8050) | 1 |
| Breadboard | 1 | DuPont Wire | 10 |

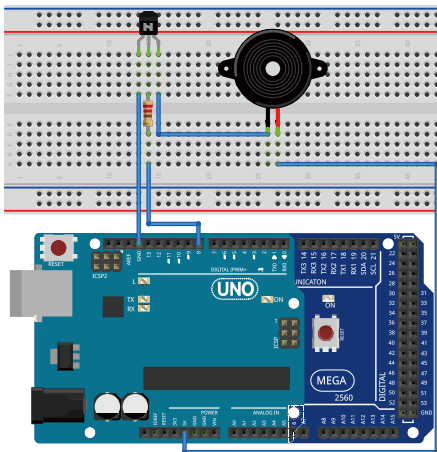
Component Introduction

A buzzer or beeper is a device which can generate audio. An active buzzer will generate a tone using an internal oscillator, so all that is needed is a DC voltage.

A transistor is a semiconductor device used to amplify or switch electronic signals and electrical power. The transistor can also be used to control the circuit conductive or disconnected. And the transistor is divided into two kinds, one is NPN like S8050, another one is PNP like S8550.



Wiring Diagram



Result

The buzzer will ring for 2s and then mute for 2s.

Lesson 6 Playing Music

Overview

In this lesson, you will learn how to program the UNO R3 or MEGA 2560 board to control a passive buzzer, and then make the passive buzzer play music.

Components Required

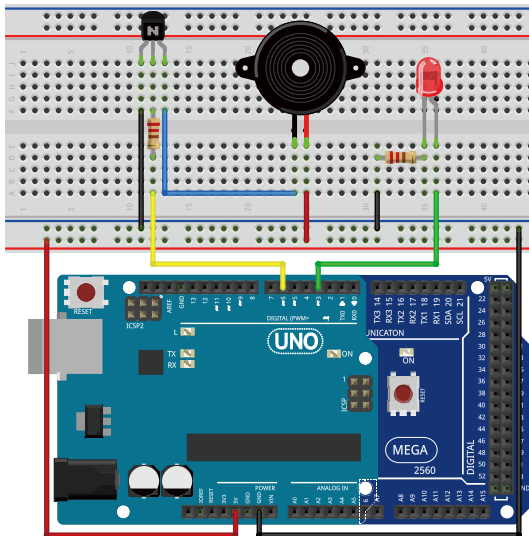
| Name | Qty | Name | Qty |
|------------------------|-----|----------------------|-----|
| UNO R3 or MEGA 2560 | 1 | 1K Ω Resistor | 3 |
| Passive Buzzer | 1 | LED | 3 |
| 220 Ω Resistor | 1 | Breadboard | 1 |
| NPN Transistor (S8050) | 1 | DuPont Wire | 10 |

Component Introduction

A passive buzzer requires an AC signal to make a sound. It is like an electromagnetic speaker, where a changing input signal produces the sound, rather than producing a tone automatically like the active buzzer. The principle of passive buzzer is using PWM to generate audio signal by making the air vibrate. As long as you change the vibration frequency appropriately, it will generate different sounds. And the frequency should be limited between 2KHz and 5KHz.



Wiring Diagram



Result

The passive buzzer will play music, and the LED blink simultaneously.

Lesson 7 Tilt Ball Switch

Overview

In this lesson, you will learn how to use a tilt ball switch in order to detect small angle of inclination.

Components Required

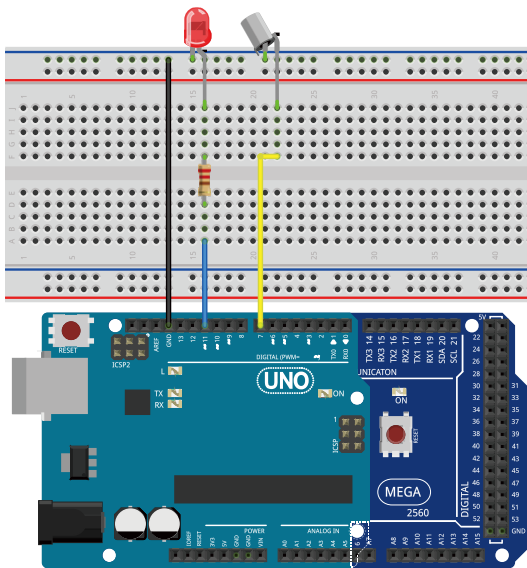
| Name | Qty | Name | Qty |
|---------------------|-----|-----------------------|-----|
| UNO R3 or MEGA 2560 | 1 | DuPont Wire | 3 |
| Tilt Ball Switch | 1 | 220 Ω Resistor | 1 |

Component Introduction

The tilt sensor is a component that can detect the tilting of an object. However it works like a normal switch but through a different physical mechanism. This type of sensor is the environmental-friendly version of a mercury-switch. It contains a metallic ball inside that will conduct the two pins on and off when the sensor reaches a certain angle and vice versa.



Wiring Diagram



Result

When the sensor tilts to a certain angle, the LED will light up. When the sensor tilts in the opposite direction, the LED will be extinguished.

Lesson 8 7-segment display

Overview

In this lesson, you will learn how to program the UNO R3 or MEGA 2560 board to control the segment display.

Components Required

| Name | Qty | Name | Qty |
|---------------------|-----|-----------------------|-----|
| UNO R3 or MEGA 2560 | 1 | 220 Ω Resistor | 1 |
| 7-Segment Display | 1 | DuPont Wire | 9 |
| Breadboard | 1 | | |

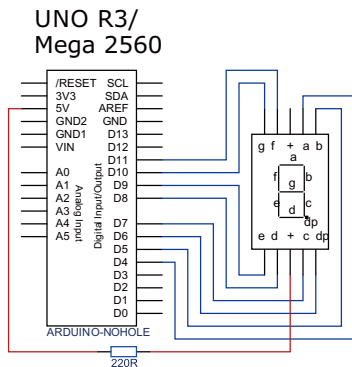
Component Introduction

The seven-segment display is a type of electronic display device for displaying decimal numbers compared to the more complex dot matrix displays. The seven-segment display is an 8-shaped LED display device composed of eight LEDs (including a decimal point), these segments respectively named a, b, c, d, e, f, g, dp shown in the figure.

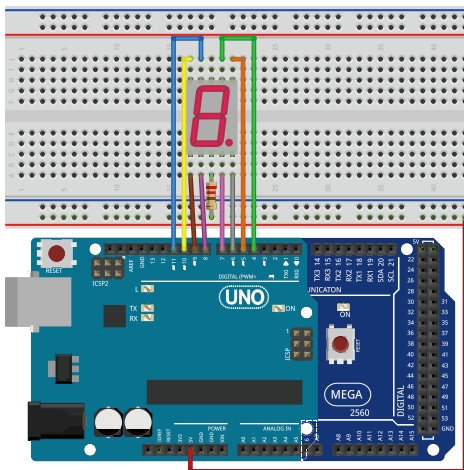


The segment display also has two types like common anode and common cathode. When using a common cathode LED, the common cathode should be connected to the ground (GND). If using a common anode, it should be connected to (VCC). Each segment is composed of LED, so a resistor is needed for protecting the LED.

Connection Schematic



Wiring Diagram



Result

The characters "1 2 3 4 5 6 7 8 9" will be shown on the 7-segment display one by one.

Lesson 9 Photoresistor

Overview

In this lesson, you will learn how to measure light intensity using an Analog Input and use the level of light to control the number of LEDs to be lit up.

Components Required

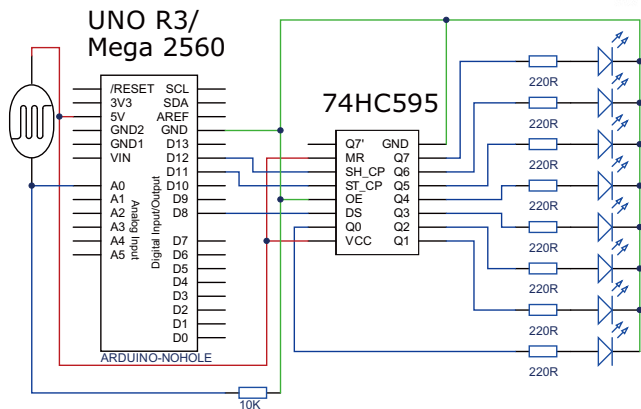
| Name | Qty | Name | Qty |
|---------------------------|-----|---------------|-----|
| UNO R3 or MEGA 2560 | 1 | LED | 8 |
| Breadboard | 1 | 220Ω Resistor | 8 |
| 74HC595 IC | 1 | 10KΩ Resistor | 1 |
| Photoresistor (Photocell) | 1 | DuPont Wire | 19 |

Component Introduction

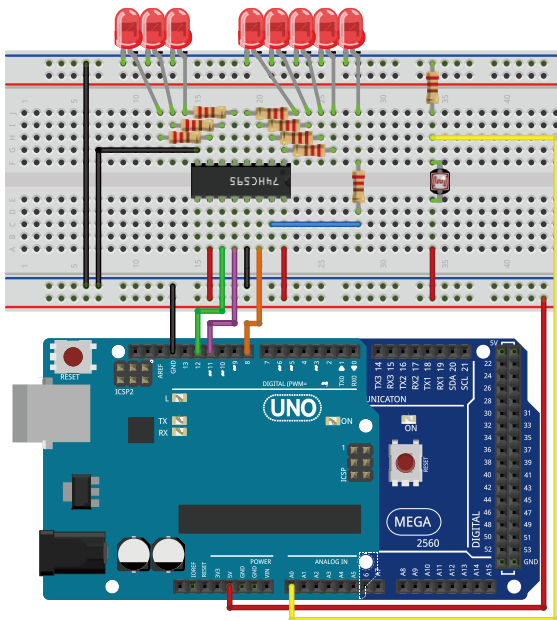
A photoresistor is a light-controlled variable resistor. The resistance of a photoresistor decreases with the increasing incident light intensity; in other words, it exhibits photoconductivity.



Connection Schematic



Wiring Diagram



Result

The stronger light the photoresistor received, the more LEDs will light up.

Lesson 10 Relay

Overview

In this lesson, you will learn how to control a relay to connect or disconnect a circuit.

Components Required

| Name | Qty | Name | Qty |
|------------------------|-----|-------------|-----|
| NPN Transistor (S8050) | 1 | Relay | 1 |
| 1K Ω Resistor | 1 | LED | 1 |
| 1N4007 Diode | 1 | DuPont Wire | 6 |
| Breadboard | 1 | | |

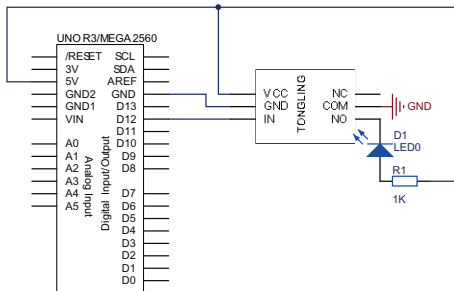
Component Introduction

A diode is a two-terminal electronic component that conducts primarily in one direction (asymmetric conductance); it has low (theoretic zero) resistance to the current in one direction, and high (theoretic infinite) resistance in the other direction.

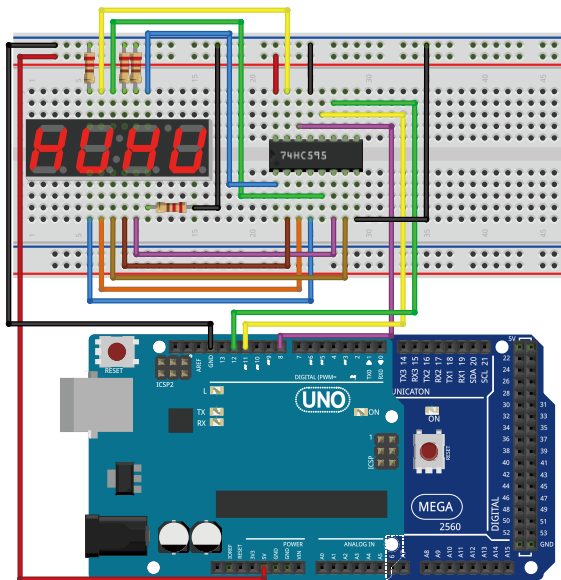
A relay is an electrically operated switch. It is generally used for automatic control. Actually, it is an "automatic switch" which uses low voltage device like Arduino to control high voltage device like 220V lamp. It plays a role of automatic regulation, security protection and circuit switch. In this lesson, we won't use any 220V device for safety reason, just use 5V LED for illustration.



Connection Schematic



Wiring Diagram



Result

The character "1 2 3 4 5 6 7 8 9 a b c d e f" shown on 4-bit 7-segment display one by one, the interval is 0.5 seconds.

Lesson 12 Servo Motor

Overview

In this lesson, you will master how to control a servo motor with the UNO R3 or MEGA 2560 board.

Components Required

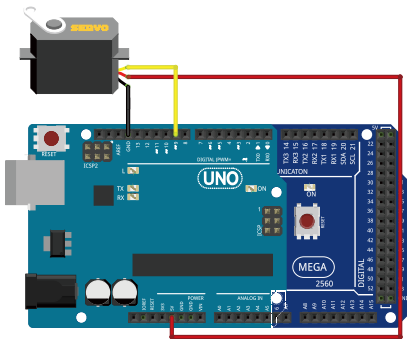
| Name | Qty | Name | Qty |
|---------------------|-----|-------------|-----|
| UNO R3 or MEGA 2560 | 1 | DuPont Wire | 3 |
| Servo (SG90) | 1 | | |

Component Introduction

Servo motor is a kind of geared motor that can rotate with a certain angle according to the input pulse's frequency and duty cycle. The input pulse frequency and duty cycle should be in a certain range for proper operation. A servo motor can usually only turn 90° in either direction for a total of 180° movement. The PWM signal can be sent to servo to move the shaft to the desired position.



Wiring Diagram



Result

After downloading the example, the servo motor turn left at 15° every second, then come back to initial position at the same speed. In next loop, it will turn left at a higher speed and then come back.

Lesson 13 DC Motor

Overview

In this lesson, you will learn how to control a small DC motor by an UNO R3 or MEGA 2560.

Components Required

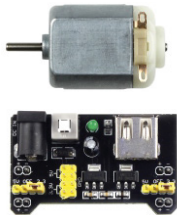
| Name | Qty | Name | Qty |
|---------------------|-----|--------------|-----|
| UNO R3 or MEGA 2560 | 1 | 3-6V Motor | 1 |
| L9110 | 1 | 9V1A Adapter | 1 |
| Power Supply Module | 1 | Fan Blade | 1 |
| Breadboard | 1 | DuPont Wire | 9 |

Component Introduction

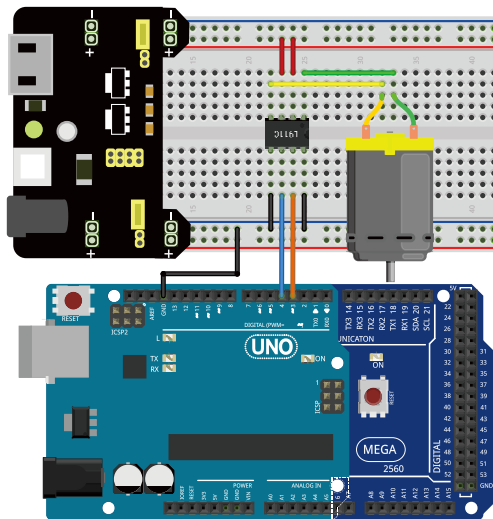
A DC motor is a kind of transducer that converts direct current electrical power into mechanical power.

To complete this lesson, an extra power supply breakout board is needed to source much more current to driver the DC motor than Arduino board can do. The board has a jumper to select 3.3V or 5V for each output. In this lesson, we only set the jumpers to 5V position as the picture shown.

L9110 is a driver IC which is used to control and drive motor with two TTL/CMOS input terminals from Arduino GPIOs.



Wiring Diagram



Result

The DC motor rotates in clockwise direction for 1s, and then rotates in counterclockwise for 1s. The action will continue to cycle. And keep on rotating like this way again and again.

Lesson 14 Stepper Motor

Overview

In this lesson, you will learn how to control a stepper motor.

Components Required

| Name | Qty | Name | Qty |
|-------------------------------------|-----|---------------|-----|
| UNO R3 or MEGA 2560 | 1 | Stepper Motor | 1 |
| ULN2003 Stepper Motor Driver Module | 1 | 9V1A Adapter | 1 |
| Power Supply Module | 1 | DuPont Wire | 12 |
| Breadboard | 1 | | |

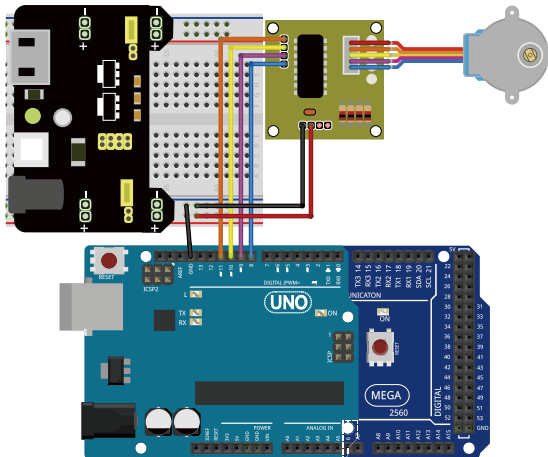
Component Introduction

A stepper motor divides a full rotation into a number of discrete steps. The motor's position can then be commanded to move and hold at one of these steps. Once stopped, the stepper holds the load steady with a holding torque. Most stepper motors employ a doubly salient design with teeth on both the rotor and stator structures. Like a brushless DC or permanent magnet synchronous motor, the permanent magnets are on the rotor and the electromagnets are in the stator.

UNO R3 board or MEGA 2560 board cannot directly drive stepper motor, so we choose an ULN2003 driver board. There are four LEDs on the module. The white socket in the middle is for connecting a stepper motor.



Wiring Diagram



Result

The stepper motor moves forward 512 steps (rotate a circle) at a high speed and move in the opposite direction at a low speed after 2s. The action will repeat again and again.

Lesson 15 Intrusion Detection by PIR

Overview

In this lesson, you will learn how to use Passive Infrared (PIR) sensor to detect the movement nearby.

Components Required

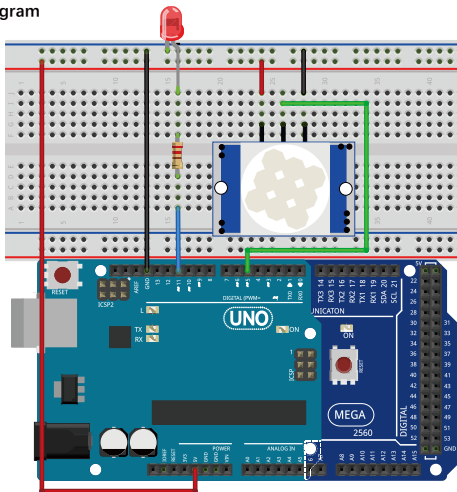
| Name | Qty | Name | Qty |
|---------------------|-----|---------------|-----|
| UNO R3 or MEGA 2560 | 1 | 220Ω Resistor | 1 |
| PIR Movement Sensor | 1 | LED | 1 |
| DuPont Wire | 1 | | |

Component Introduction

PIR sensors respond to heat and can be triggered by the heat source such as animals as well as people. The output of Passive Infrared (PIR) sensor will go high when the motion has been detected.



Wiring Diagram



Result

When someone stands within the sensing range of the module, the LED will light up and delay for a while. When the person exits the sensing range, the LED will turn off after some time delay. In addition, the delay time and detection distance can be adjusted by the resistors on PIR module.

Lesson 16 1602 LCD Display

Overview

In this lesson, you will learn how to use a character display device 1602 LCD on the UNO and MEGA 2560 board.

Components Required

| Name | Qty | Name | Qty |
|---------------------|-----|----------------|-----|
| UNO R3 or MEGA2560 | 1 | LCD1602 Module | 1 |
| Potentiometer (10k) | 1 | DuPont Wire | 16 |
| Breadboard | 1 | | |

Component Introduction

During the building of your projects for Arduino, you'll often need to read the output data directly from a LCD display.

The display has backlight and can display two rows with up to 16 characters on each row.



The integration of the LCD display greatly facilitates the interactivity of the project you are developing, allowing the user to read some output parameters directly.

The interface of the LCD consists of the following pins:

VSS: Connect to ground.

VDD: Connect to +5V power supply .

VO: Adjust the contrast of 1602 LCD display. An external potentiometer is always used to adjust the contrast.

RS: A register selection pin that controls the location of data written in the LCD memory. You can select the data register, which holds the contents of the screen, or select an instruction register, which is the instruction for the LCD controller to find out what to do next.

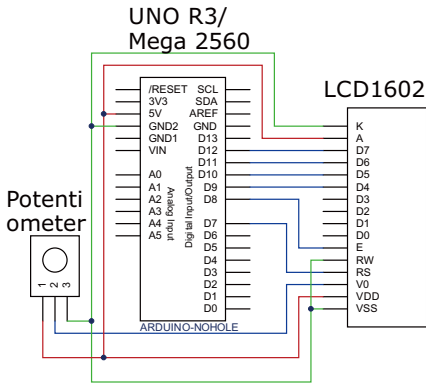
R/W: A Read/Write pin that selects reading mode or writing mode

E: When an enabling pin supplied with low-level energy, the LCD module will execute relevant instructions.

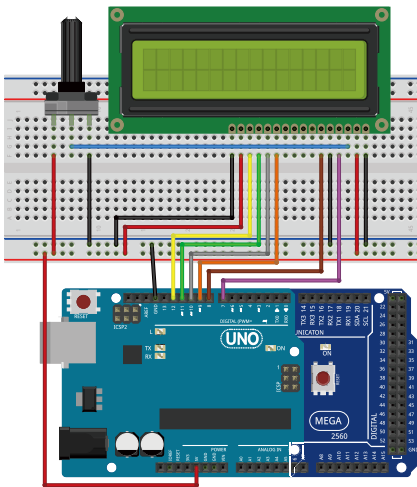
D0-D7: Read and write data

A and K: Control the LED backlight

Connection Schematic



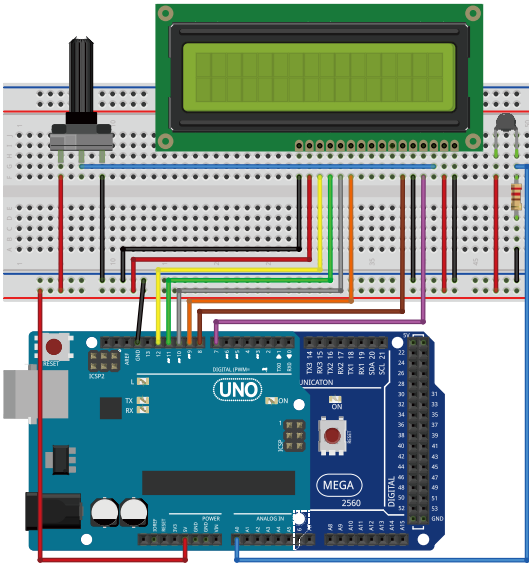
Wiring Diagram



Result

The characters "Hello, World" will be shown on the first line of the LCD module, and the second line is the running time (in second).

Wiring Diagram



Result

The current real-time temperature in degrees will be shown on the LCD display as "TEMP XX F". The default unit is Fahrenheit. You can try to replace only two functions to change it to Celsius (functions are in the code annotation).

Lesson 18 Temperature & humidity sensor DHT-11

Overview

In this lesson, you will learn how to use a DHT11 Temperature and Humidity Sensor. It's accurate enough for most of projects that need to measure humidity and temperature.

Components Required

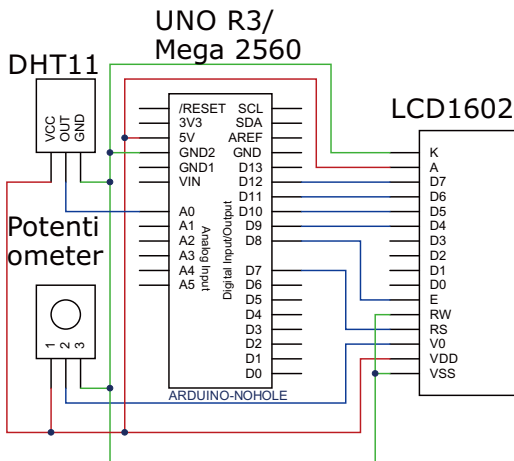
| Name | Qty | Name | Qty |
|----------------------------|-----|----------------------------|-----|
| UNO R3 or MEGA 2560 | 1 | DuPont Wire | 20 |
| DHT11 Temp and Humi Module | 1 | 10K Ω Potentiometer | 1 |

Component Introduction

The DHT11 Sensor features a temperature & humidity sensor complex with a calibrated digital signal output. The sensor includes a resistive-type humidity measurement and an NTC temperature measurement.



Connection Schematic



Lesson 19 Joystick Module

Overview

In this Lesson, you will learn how to use the analog joystick module.

Components Required

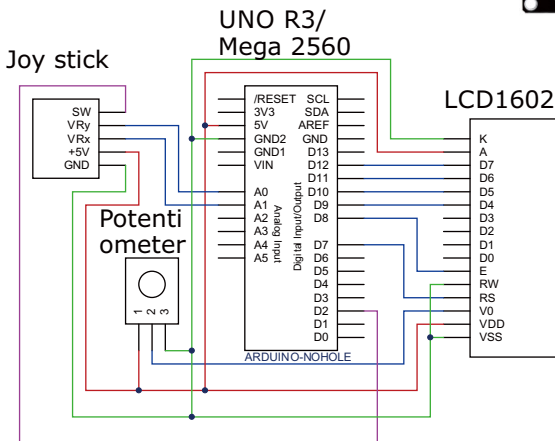
| Name | Qty | Name | Qty |
|---------------------|-----|----------------------------|-----|
| UNO R3 or MEGA 2560 | 1 | 10K Ω Potentiometer | 1 |
| LCD1602 | 1 | Joy Stick | 1 |
| DuPont Wire | 21 | Breadboard | 1 |

Component Introduction

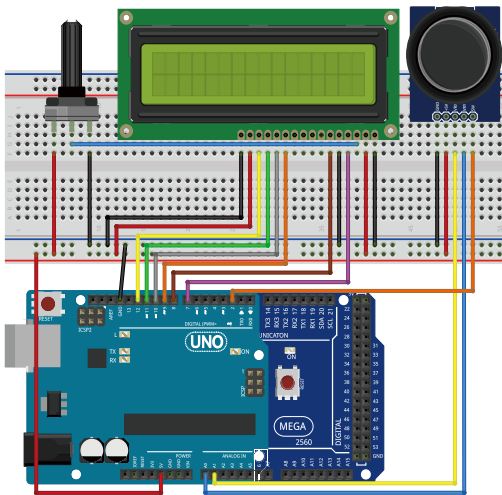
A joystick is an input device consisting of a stick that pivots on a base and reports its angle or direction to the device under its control.



Connection Schematic



Wiring Diagram



Result

There're 3 values "X Y Z" shown on the LCD display module. Push down the joystick, Y will increase accordingly, and vice versa; push the joystick to the right, X will increase, and vice versa. By pressing the joystick, the value of Z will change from 1 to 0. You can use this module in many interesting projects, such as remote control cars.

Lesson 20 Ultrasonic Sensor Module

Overview

In this lesson, you will learn how to measure the distance by the ultrasonic distance sensor.

Components Required

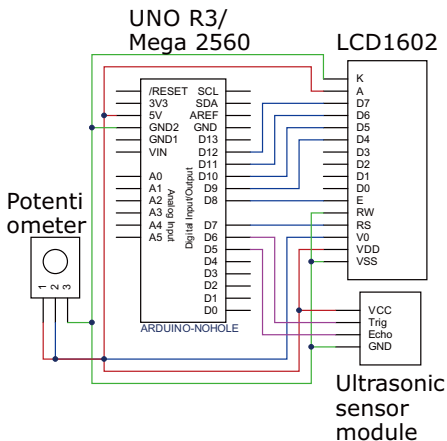
| Name | Qty | Name | Qty |
|--------------------------|-----|----------------------------|-----|
| UNO R3 or MEGA2560 | 1 | LCD1602 | 1 |
| Ultrasonic Sensor Module | 1 | 10K Ω Potentiometer | 1 |
| DuPont Wire | 20 | | |

Component Introduction

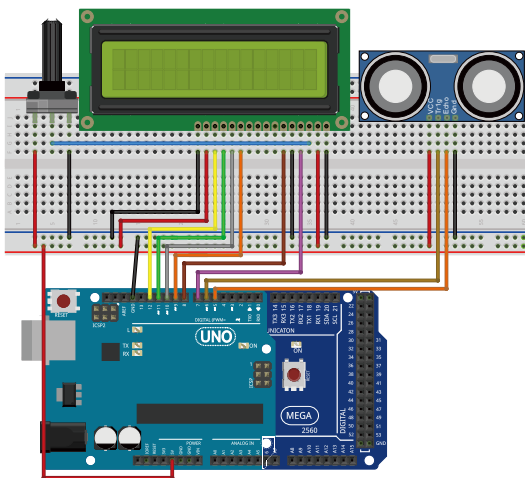
The HC-SR04 ultrasonic sensor is a device that can measure the distance to an object by using sound waves. It measures distance by sending out a sound wave at a specific frequency and listening for that sound wave to bounce back. By recording the elapsed time between the sound wave being generated and the sound wave bouncing back, it is possible to calculate the distance between the sonar sensor and the object.



Connection Schematic



Wiring Diagram



Result

When the ultrasonic module is aimed at the obstacle, the distance will be displayed on the LCD module.

Lesson 21 IR Remote Controller

Overview

In this lesson, you will learn how to use an IR receiver to receive the remote controller signal.

Components Required

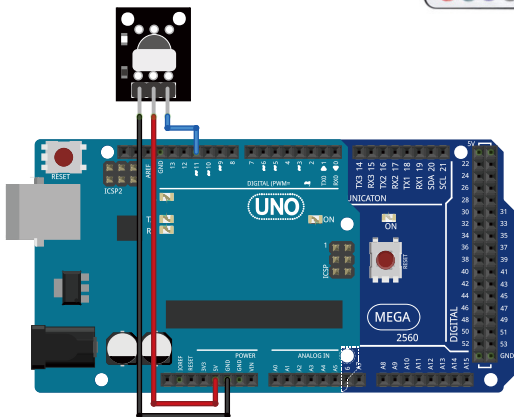
| Name | Qty | Name | Qty |
|----------------------|-----|----------------------------|-----|
| UNO R3 or MEGA 2560 | 1 | IR Receiver Module | 1 |
| IR Remote Controller | 1 | Female to Male DuPont Wire | 3 |

Component Introduction

The universal infrared remote controlling system consists of two parts: sending and receiving, the sending part consists of an IR remote controller, the receiving part consists of an infrared receiving tube.

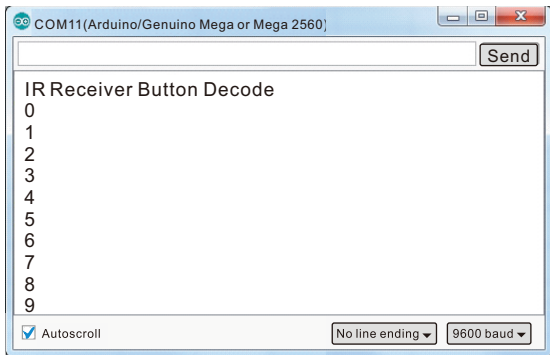


Wiring Diagram



Result

Open serial monitor. Then, press the 0-9 key on the remote controller and you' d better to keep the controller pointing at the IR receiver at the same time, then the corresponding number will be shown on the serial monitor like the following picture.



Lesson 22 LED bar graph display

Overview

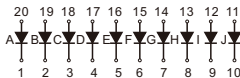
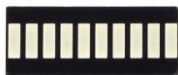
In this lesson, you will learn how to control a LED bar graph in a row

Components Required

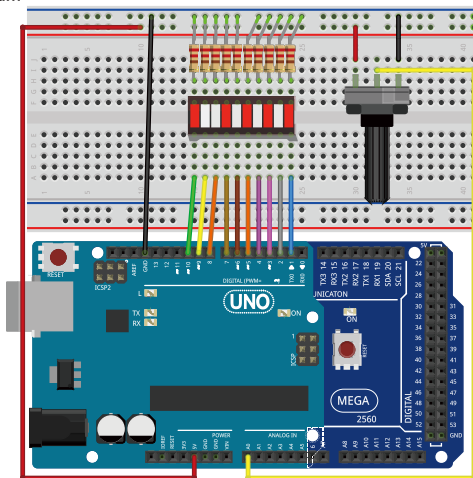
| Name | Qty | Name | Qty |
|-----------------------|-----|----------------------------|-----|
| UNO R3 or MEGA 2560 | 1 | 10K Ω Potentiometer | 1 |
| 220 Ω Resistor | 1 | LED Bar Graph | 1 |
| Breadboard | 1 | DuPont Wire | 15 |

Component Introduction

The bar graph is made of 10 independent LEDs in a row. Internal schematic diagram for the LED bar graph shows in the right picture. In this lesson, we will use a potentiometer to change the input voltage of an analog pin. Then Arduino read the voltage and display the voltage level on the LED bar display.



Wiring Diagram



Result

When you turn the potentiometer to the right, The Input voltage of A0 will become larger. You will see that the LEDs are lit from right to left. If you turn the potentiometer to the left, then the LED will turn off from left to right.

Lesson 23 4*4 Matrix Keyboard

Overview

In this lesson, you will learn how to use the matrix keyboard.

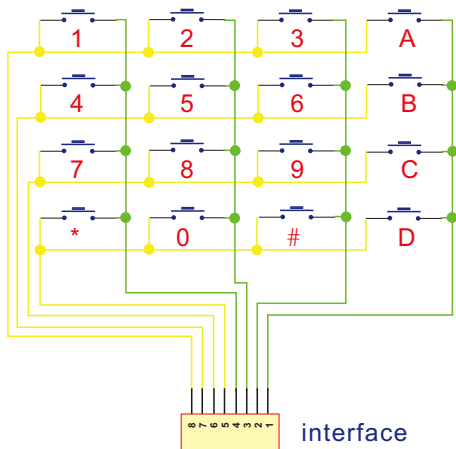
Components Required

| Name | Qty | Name | Qty |
|--------------------------|-----|---------------------|-----|
| UNO R3 or MEGA 2560 | 1 | 4*4 Matrix Keyboard | 1 |
| Male to Male DuPont Wire | 8 | | |

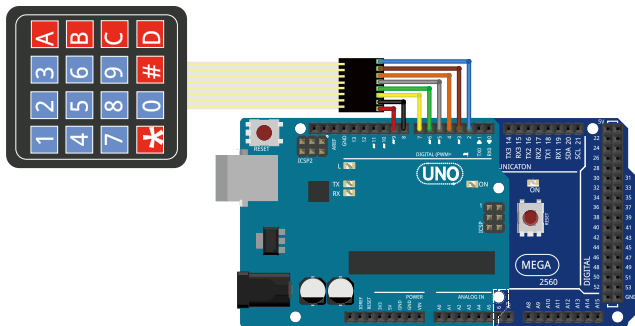
Component Introduction

This 16-button keypad provides a useful human interface for micro-controller projects. The convenient adhesive backing provides a simple way to mount the keypad in various applications.

Schematic of 4x4 matrix keyboard shows in the following picture.

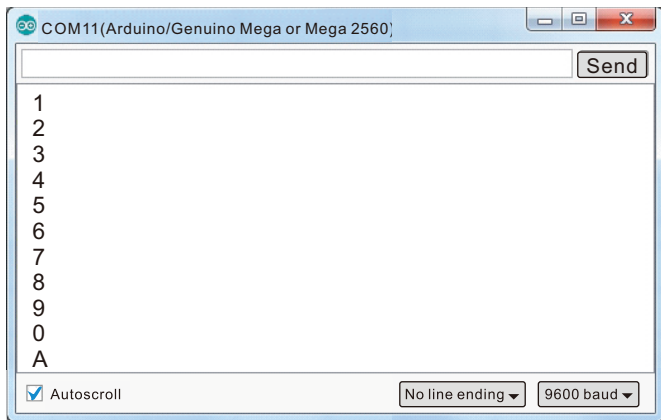


Wiring Diagram



Result

Open the serial monitor, then press any keys on the 4*4 matrix keyboard, the corresponding key value will be displayed in the serial monitor.



Lesson 24 Real Time Clock Module

Overview

In this lesson, you will learn how to use the DS3231 Real Time Clock Module.

Components Required

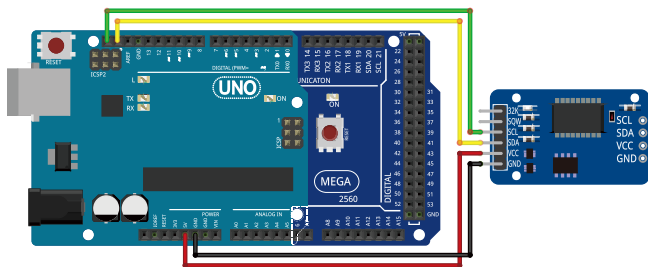
| Name | Qty | Name | Qty |
|---------------------|-----|-------------------|-----|
| UNO R3 or MEGA 2560 | 1 | DS3231 RTC Module | 1 |
| DuPont Wire | 4 | | |

Component Introduction

The DS3231 is a low-cost, extremely accurate I2C real-time clock (RTC) with an integrated temperature compensated crystal oscillator (TCXO) and crystal. The device incorporates an onboard battery which maintains accurate timekeeping even when unplugged. The RTC module can output seconds, minutes, hours, day, date, month, and year information.

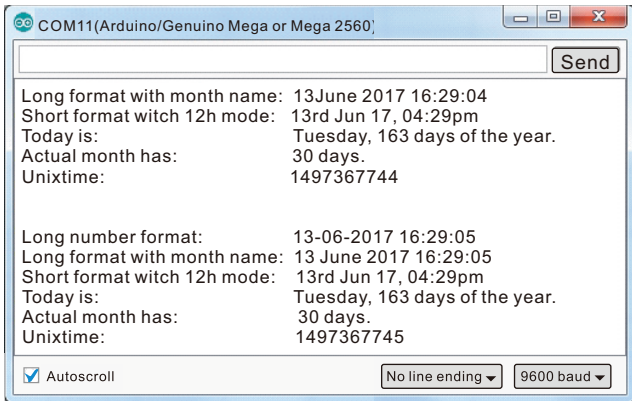


Wiring Diagram



Result

Open the serial monitor, the date will refresh every second. You can power off the board and connect again to check if the time remain walking. The RTC module should continue to walk even if it is powered off.



Lesson 25 Water Level Detection Sensor Module

Overview

In this lesson, you will learn how to use a water level detection sensor module.

Components Required

| Name | Qty | Name | Qty |
|-------------------------------------|-----|-------------|-----|
| UNO R3 or MEGA 2560 | 1 | DuPont Wire | 3 |
| Water Level Detection Sensor Module | 1 | | |

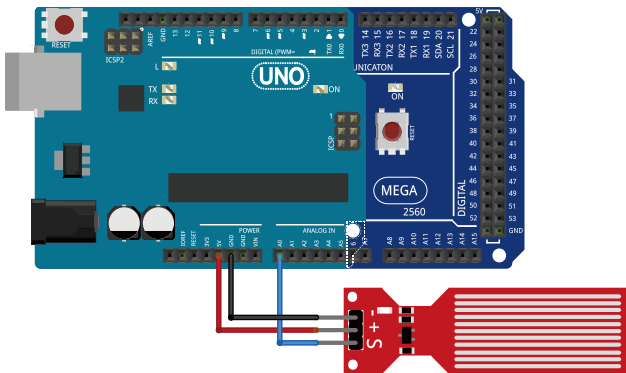
Component Introduction

The water sensor water level module can perceive water by measuring the volume of droplets water through a series of parallel lines exposed parallel traces in order to determine the water level.



When insert it into the water, those parallel lines will generate a resistor that can change along with the depth of water. Then, the signal of water's depth is converted into the electrical signal, and we can get the changes through the ADC function from UNO R3 or MEGA 2560.

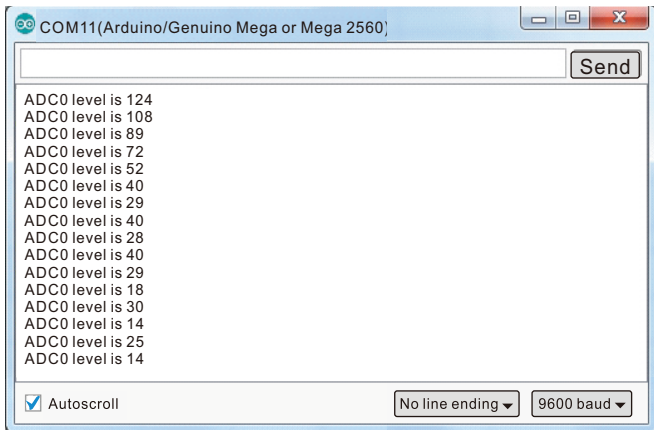
Wiring Diagram



Result

Open the serial monitor. Insert the water level detection sensor module into water, you will see that the data displayed in the serial monitor, which represent the depth of the module immersed in water. (Unit: 1/10 mm)

Note: Don't immerse the module in water too deep to avoid short circuits.



Lesson 26 Sound Sensor Module

Overview

In this lesson, you will learn how to use a sound sensor module.

Components Required

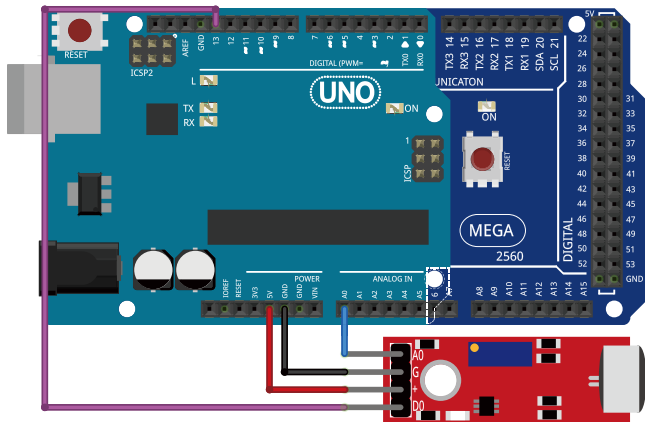
| Name | Qty | Name | Qty |
|---------------------|-----|----------------------------|-----|
| UNO R3 or MEGA 2560 | 1 | Female to Male DuPont Wire | 4 |
| Sound Sensor Module | 1 | | |

Component Introduction

Sound Sensor can detect the sound strength of the environment. The main component of the module is a simple microphone. To make sure the microphone can detect your voice properly, please try to change its sensitivity by turning the blue precise potentiometer on the module. Due to its preciseness, it takes at least 10 circles for you to get some changes.

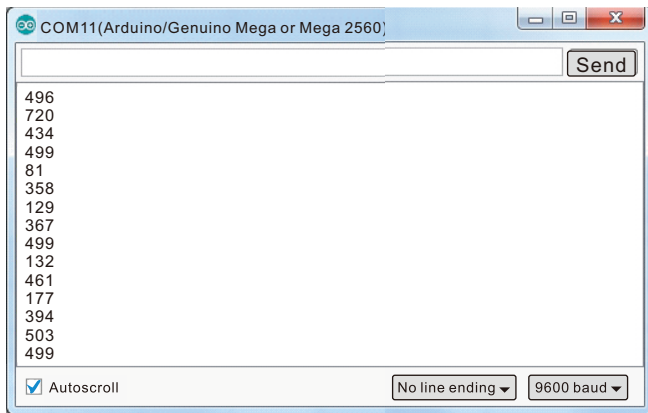


Wiring Diagram



Result

Open serial monitor. Speak to the microphone on the sound sensor module, the value of the volume will be displayed in the serial monitor.



Lesson 27 MAX7219 LED Dot Matrix Module

Overview

In this lesson, you will learn how to control an 8x8 dot-matrix display to implement the display of graphical characters or digits you want.

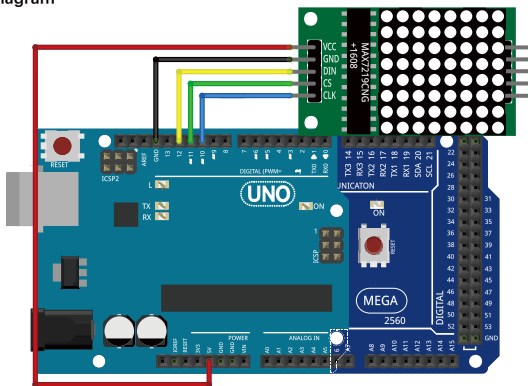
Components Required

| Name | Qty | Name | Qty |
|---------------------|-----|-------------|-----|
| UNO R3 or MEGA 2560 | 1 | DuPont Wire | 5 |
| Max7219 Module | 1 | | |

Component Introduction

This is an 8x8 LED matrix module which serially driven by the MAX7219 common-cathode display drivers. The 8x8 LED Matrix is easy to use and compatible with Arduino, only needs three data lines and two power lines. It can be used in lots of place like various types of electronic display panels.

Wiring Diagram



Result

The characters "UCTRONICS" will be displayed on the LED dot matrix module and then the LEDs light up line by line. And repeat this way again and again.

Lesson 28 Frequency Meter

Overview

In this lesson, you will learn to build a simple frequency meter with UNO R3 or MEGA 2560. The frequency of square wave is generated by 555 timer, and then it will be sent to the Arduino GPIO pin, the result to serial monitor through USB port.

Components Required

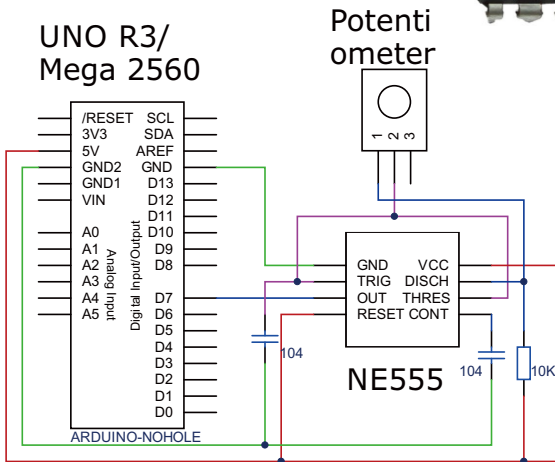
| Name | Qty | Name | Qty |
|---------------------|-----|--------------------|-----|
| UNO R3 or MEGA 2560 | 1 | 10KΩ Potentiometer | 1 |
| NE555 Timer | 1 | 104 Capacitor | 2 |
| 10KΩ Resistor | 1 | Breadboard | 1 |
| DuPont Wire | 13 | | |

Component Introduction

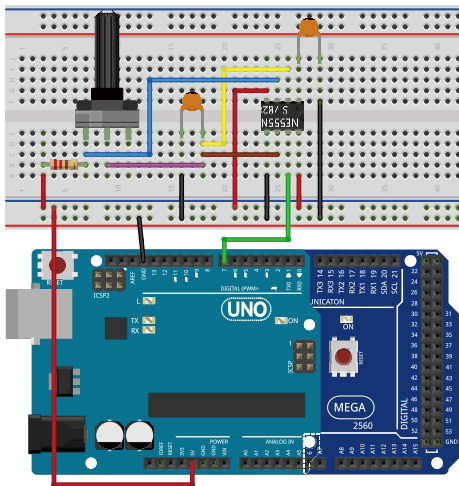
The NE555 Timer is an integrated circuit (chip) used in a variety of applications like timer, pulse generation, and oscillator.



Connection Schematic

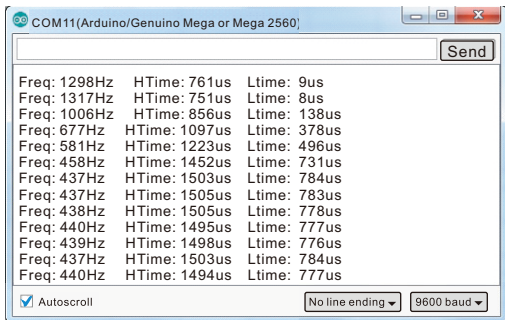


Wiring Diagram



Result

Open the serial monitor, the value of square wave frequency, time of high level and low level will be displayed. Turning the potentiometer, the value of frequency will be changed accordingly.



Lesson 29 MPU-6050 Module

Overview

In this lesson, you will learn how to use MPU6050 module (Inertia Measurement Unit)

Components Required

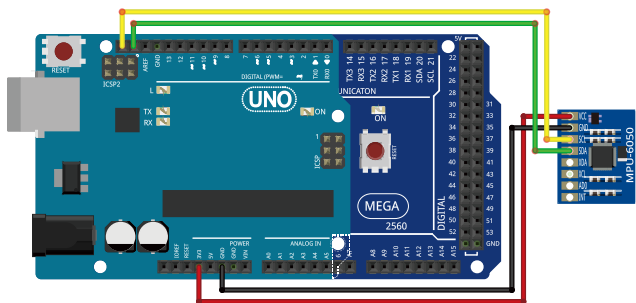
| Name | Qty | Name | Qty |
|---------------------|-----|----------------|-----|
| UNO R3 or MEGA 2560 | 1 | MPU6050 Module | 1 |
| DuPont Wire | 4 | | |

Component Introduction

The MPU-6050 sensor contains a 3-axis MEMS accelerometer and a 3-axis MEMS gyro in a single chip. The 3 axis are represent the X,Y,Z direction each, so it can sense both velocity of acceleration and rotation in all direction. With attitude fusion algorithm software, we can calculate the movement of the object to be sensed. The sensor uses the I2C-bus to interface with the Arduino.

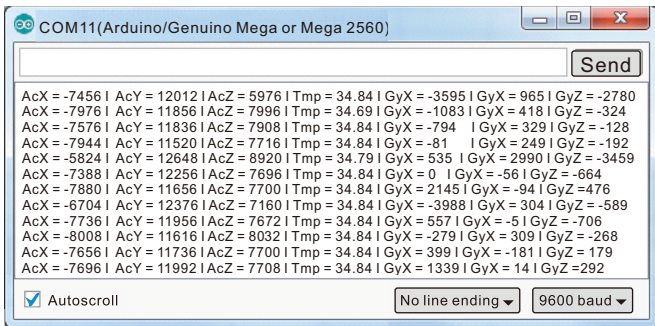


Wiring Diagram



Result

Open the serial monitor. The value of the acceleration and angular velocity of the X-axis, Y-axis and Z-axis as well as the real-time temperature will be displayed. Turning the MPU6050 module, the values will be changed accordingly.



Lesson 30 Controlling Stepper Motor with Remote

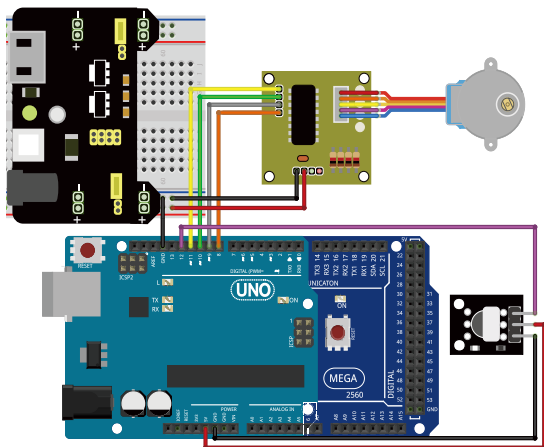
Overview

In this lesson, you will learn a fun and easy way to control a stepper motor from a distance using an IR remote control.

Components Required

| Name | Qty | Name | Qty |
|----------------------|-----|-------------------------------------|-----|
| UNO R3 or MEGA 2560 | 1 | Stepper Motor | 1 |
| IR Receiver Module | 1 | ULN2003 Stepper Motor Driver Module | 1 |
| IR Remote Controller | 1 | Power Supply Module | 1 |
| 9V1A Adapter | 1 | Breadboard | 1 |
| DuPont Wire | 15 | | |

Wiring Diagram



Result

When you press the key “1” on the IR remote controller, the stepper motor will rotate for two seconds. When you press key “2”, it will rotate in opposite direction for two seconds.

Lesson 31 Controlling Stepper Motor with Rotary Encoder

Overview

In this lesson, you will learn how to control stepper motors using a rotary encoder.

Components

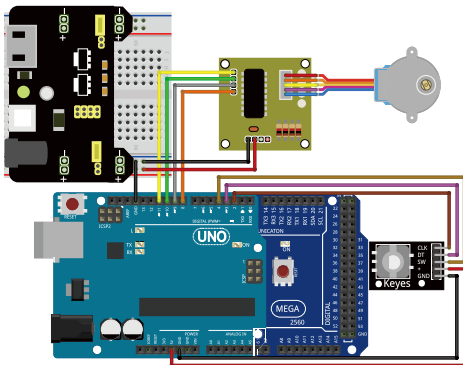
| Name | Qty | Name | Qty |
|-----------------------|-----|-------------------------------------|-----|
| UNO R3 or MEGA 2560 | 1 | Stepper Motor | 1 |
| Rotary Encoder Module | 1 | ULN2003 Stepper Motor Driver Module | 1 |
| Power Supply Module | 1 | 9V1A Adapter | 1 |
| DuPont Wire | 17 | Breadboard | 1 |

Component Introduction

A rotary encoder, also called a shaft encoder, is an electro-mechanical device that converts the angular position or motion of a shaft or axle to an analog or digital code. There are two main types: absolute and incremental (relative). The output of absolute encoders indicates the current position of the shaft, working as angle transducers. The output of incremental encoders provides information about the movement of the shaft.



Wiring Diagram



Result

Rotating the rotary encoder, the stepper motor will rotate in the same direction accordingly.

Lesson 32 ESP8266

Overview

The ESP-01S ESP8266 WiFi Module is a self-contained SOC with integrated TCP/IP protocol stack that can let any microcontroller access to your WiFi network. The ESP-01S ESP8266 module comes with pre-programmed AT command set firmware which means that you can simply hook it up to your Arduino directly.

In this lesson, you will learn how to use ESP8266 to build a WIFI remote control system.

Components Required

| Name | Qty | Name | Qty |
|-----------|-----|----------------|-----|
| MEGA 2560 | 1 | ESP8266 Module | 1 |
| Relay | 1 | DuPont Wire | 9 |

An Android app should be downloaded and installed to work with the lesson32 and lesson33 projects. It can communicate with UNO or MEGA2560 by the ESP8266 on-board WiFi to control the relay and motor. It can also read the temperature and humidity from the sensors.

Step 1 Open the code from lesson 32 and change the SSID and the PASSWORD to match your home WIFI network.

```
#define SSID "KK" // type your own SSID name
#define PASSWORD "12345687" // type your own WIFI password

#define Temp_maxlimit 29 // type your Maximum temperature
#define Temp_minlimit 28 // type your Minimum temperature
```

Step 2 The following dialog box will appear when the ESP8266 accessed WiFi successfully. The IP address shows after the "STAIP" string will be used in the next step, please write it down.



COM11(Arduino/Genuino Mega or Mega 2560)

AT+RST

Module is ready

reboot wifi is OK

+CIFSR:STATP,"192.168.2.200"+CIFSR:STAMAC,"5c:cf:7f:8f:20:3b"OK

Server is set up

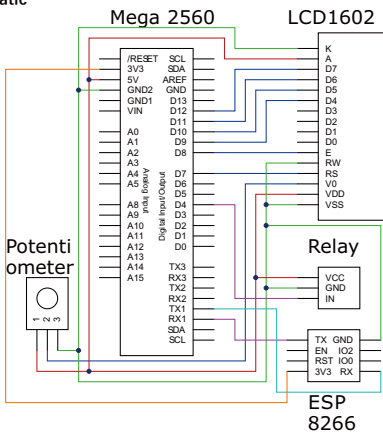
Step 3 Please check the following link to download the APP.

https://github.com/UCTRONICS/uctronics_arduino_kits/tree/master/App

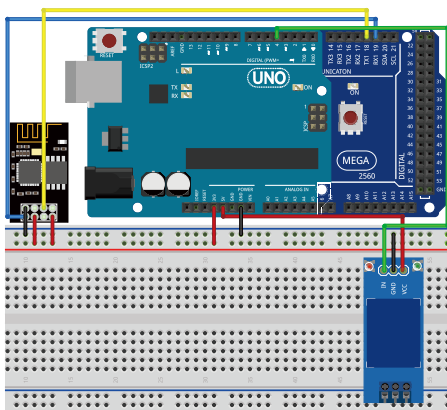
Use your phone to access the ESP8266 on-board WiFi. Open the app, you will see the following app screenshot. There're three buttons "ON OFF MODE" for controlling the hardware.



Connection Schematic

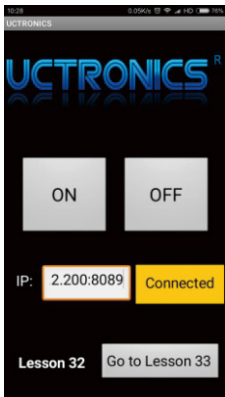


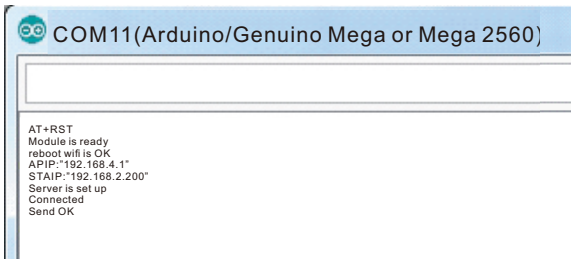
Wiring Diagram



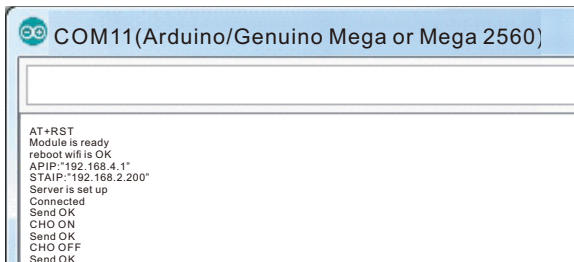
Result

Click the IP box and enter the IP address (got from Step2) + ":8089", like "192.168.2.200:8089" (Input without quote). Then click the button CONNECT, it will become yellow and show the character CONNECTED. The status of connection will also be shown in the serial monitor. That means the app has communicated with UNO or MEGA2560 through ESP8266 on-board WiFi successfully.





Next, click button ON, the relay will be switched on, that means the port COM is connected to the port NO. Click the button OFF, the relay will close, that means the port COM is connected to the port NC. The status of the relay will also be shown in the serial monitor.



Lesson 33 Building a Smart Home System

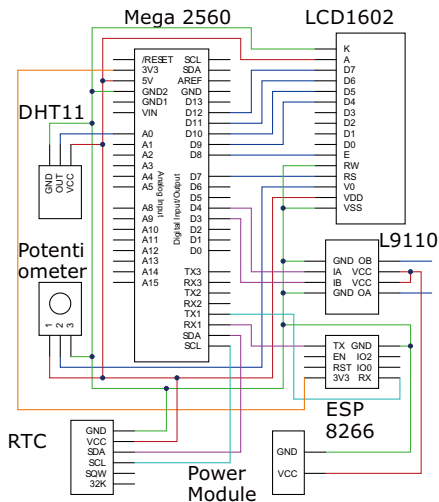
Overview

In this lesson, you will learn to build a smart home system with ESP8266 and sensors. You can also use the same idea to develop other interesting projects.

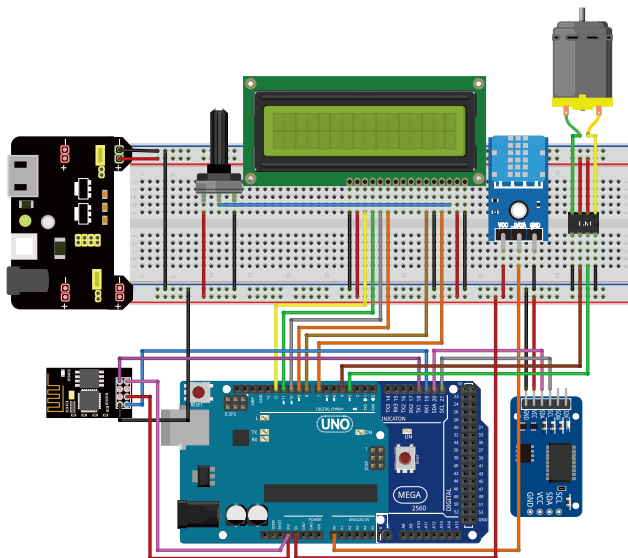
Components Required

| Name | Qty | Name | Qty |
|----------------------------|-----|---------------------|-----|
| MEGA 2560 | 1 | ESP8266 Module | 1 |
| DS3231 RTC module | 1 | LCD1602 | 1 |
| Fan blade | 1 | 3-6v Motor | 1 |
| L9110 | 1 | Power Supply Module | 1 |
| 9V1A Adapter | 1 | Breadboard | 1 |
| DHT11 Temp and Humi module | 1 | DuPont Wire | 32 |

Connection Schematic



Wiring Diagram



Result

Open the code from lesson 33 and change the SSID and the PASSWORD to match your home WIFI network. Then connect the app to Arduino board using the same steps from the lesson 32.

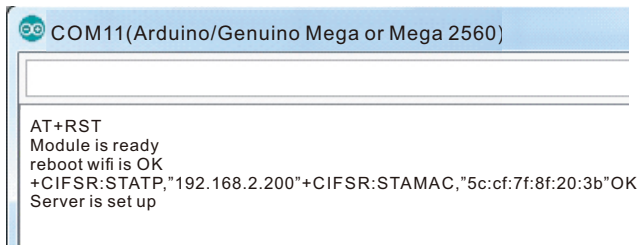
After successful connection, the RTC time will be displayed on the first line of the 1602 LCD.

The value of current humidity and temperature will be displayed on the second line.

The value will also be shown in app after a while.



The MODE button is used to switch between manual mode or automatic mode. The mode will be displayed on the 1602 LCD for 1s when switching. It will be shown in the serial monitor as well.



```
COM11(Arduino/Genuino Mega or Mega 2560)
AT+RST
Module is ready
reboot wifi is OK
+CIFSR:STATP,"192.168.2.200"+CIFSR:STAMAC,"5c:cf:7f:8f:20:3b"OK
Server is set up
```

In automatic mode, if the temperature is higher than the value of Temp_maxlimit, the motor and fan will start working. They will not stop until the temperature is lower than the value of Temp_minlimit.

```
#define Temp_maxlimit 29           // type your Maximum temperature
#define Temp_minlimit 28          // type your Minimum temperature
```

In manual mode, the motor and fan can only be controlled by the APP Click "ON" and "OFF" to make the motor work or not.

Note:

1. Don't keep the motor working for a long time to prevent L9110 over heat.
2. If the time shown on the 1602 LCD is wrong, please open the file calibration-clock under the file of lesson33. Then download Calibration_clock.ino to check the time. Next, re-compile and download the code of lesson 33, you can get the right time.